

# TECNOAL

MECHANICAL ENGINEERING  
FOR ELECTRONICS

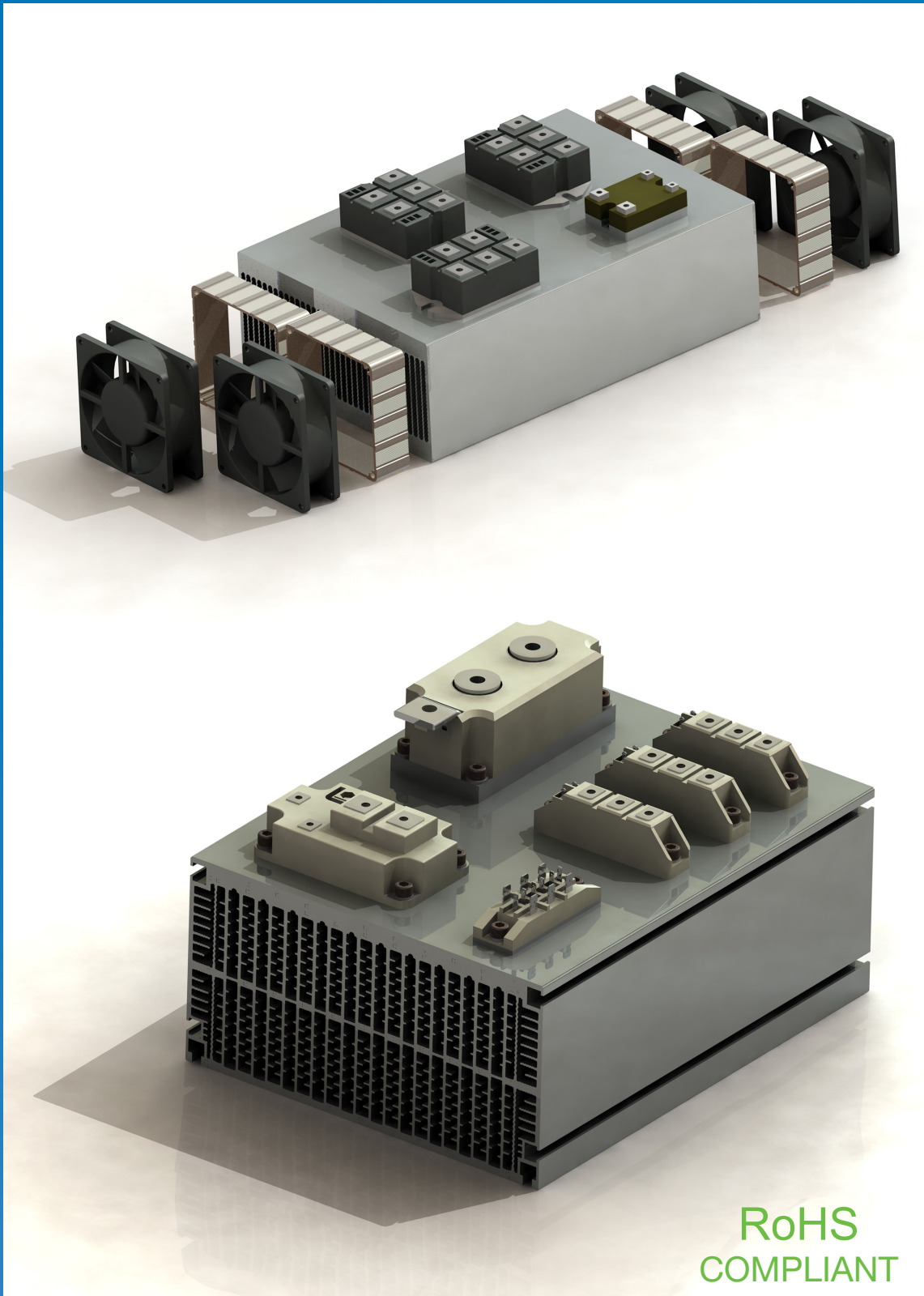

RoHS  
COMPLIANT

TECNOPOWER ASSEMBLY HEATSINK



# DET NORSKE VERITAS

## QUALITY MANAGEMENT SYSTEM CERTIFICATE

Certificato No. / Certificate No. **CERT-10548-2002-AQ-BOL-SINCERT**

*Si attesta che / This certifies that*

*Il sistema di gestione per la qualità di / the quality management system of*

**TECNOAL S.n.c.**

**Via Bonazzi, 19/21 - 40013 Castel Maggiore (BO) - Italy**

*È conforme ai requisiti della norma per i sistemi di gestione per la qualità  
Conforms to the quality management systems standard*

**UNI EN ISO 9001:2008 (ISO 9001:2008)**

*Questa certificazione è valida per il seguente campo applicativo:*

*This certificate is valid for the following products or services:*

(Ulteriori chiarimenti riguardanti lo scopo e l'applicabilità dei requisiti della normativa si possono ottenere consultando l'organizzazione certificata)  
(Further clarifications regarding the scope and the applicability of the requirements of the standard(s) may be obtained by consulting the certified organization)

**Progettazione e produzione di dissipatori e supporti meccanici per componenti elettronici**

**Design and manufacture of dissipators and mechanical accessories for electronic components**

Data Prima Emissione

First Issue Date

**2002-05-14**

Luogo e data

Place and date

**Agrate Brianza, (MB) 2011-03-28**

**Settore EA : 17**

**Corrado Stefani**

Lead Auditor

Data di scadenza

Expiry Date

**2014-05-07**



SGQ N°003 A PRD N°003 B  
SGA N°003 D SSI N°002 G  
SCR N°004 F FSM N°001 I

Membro di MLA EA per gli schemi di accreditamento SGQ, SGA, PRD, PRS, ISP e LAB, di MLA IAF per gli schemi di accreditamento SGQ, SGA, SSI, FSM e PRD e di MRA ILAC per gli schemi di accreditamento LAB

per l'Organismo di Certificazione  
for the Accredited Unit

**DET NORSKE VERITAS ITALIA S.R.L.**

**Zeno Beltrami**

Management Representative

Gent.le Cliente

mi permetto di presentarLe l'azienda.

Tecnoal è stata fondata nel 1985 da persone che operavano già da un ventennio nel settore della progettazione meccanica asservita all'elettronica e a quella di potenza in particolare.

L'azienda è specializzata nelle lavorazioni meccaniche sull'alluminio; attualmente vengono lavorate e gestite circa 1000 tonnellate annue. L'attuale insediamento, ubicato nella zona industriale di Castel Maggiore, nell'immediata periferia di Bologna è costituito da circa 4500 mq coperti.

Il parco macchine di cui l'azienda dispone è composto da una decina di troncatrici veloci, specifiche per alluminio, altrettante presse di vario tonnellaggio, una decina di centri di lavoro verticali, da 4 fresatrici tradizionali di varie dimensioni, più svariati trapani e filettatrici di contorno.

La Tecnoal, nel 2002 ha conseguito la certificazione del sistema di qualità secondo le norme UNI EN ISO 9001:2008 e, conscia delle esigenze dei clienti e del mercato, ha pianificato ingenti investimenti in mezzi produttivi.

Di recente è stata destinata un'area considerevole alle lavorazioni di saldatura, implementando quella classica a TIG con una nuova linea completamente automatica e computerizzata. Questa importante scelta di investimento è finalizzata a garantire un processo più controllato, a ridurre i tempi di produzione e i relativi costi.

Si è proceduto alla razionalizzazione di tutto il settore delle lavorazioni a controllo numerico, inserendo nuove macchine interfacciandole con sistemi cad-cam e standardizzando l'intero settore al fine di accelerare i tempi produttivi e di prototipazione.

Nei programmi della direzione aziendale è ai primi posti l'estensione di tale politica innovativa anche a tutti gli altri settori produttivi. In azienda operano circa 45 dipendenti e Tecnoal cura direttamente ed esegue tutte le fasi produttive dal ricevimento delle materie prime (barre estruse) fino alla spedizione al cliente finale.

Vengono quindi eseguite internamente operazioni quali il taglio del materiale, le varie lavorazioni meccaniche, sia quelle a controllo numerico che quelle tradizionali, come la foratura, filettatura, o fresatura, eventuali assemblaggi, il lavaggio e l'imballo.

Unica lavorazione che Tecnoal affida a partner esterni ma che gestisce e supervisiona accuratamente sono gli eventuali trattamenti superficiali dei materiali, quali anodizzazione anodica, verniciatura, alodine, zincatura, argentatura ecc...

Tutti i nostri prodotti sono conformi alla normativa RoHS.

In attesa di poterLe presentare personalmente l'azienda ed i collaboratori che vi operano, Voglia gradire i più cordiali saluti.

Managing Director

Paolo Poppi

**TECNOAL s.n.c.**

Via C. Bonazzi n. 19-21

40013 Castel Maggiore

Bologna ITALY

☎ Tel. +39 051- 7092301

☎ Fax. +39 051- 702335

✉ [info@tecnoal.it](mailto:info@tecnoal.it)

✉ [tecnico@tecnoal.it](mailto:tecnico@tecnoal.it)

✉ [cnc@tecnoal.it](mailto:cnc@tecnoal.it)

✉ [amministrazione@tecnoal.it](mailto:amministrazione@tecnoal.it)

✉ [magazzino@tecnoal.it](mailto:magazzino@tecnoal.it)



Dear Customer,

I'd like to introduce to You our company.

TECNOAL is a company established in 1985 by a team of specialists, who have been working in the field of mechanical design for electronic high power applications for over twenty years.

Tecnoal is skilled in aluminium mechanical machining; currently about 1000 tons per year are processed and managed.

The factory is located in Castel Maggiore near Bologna with a floor area of 4500 sqm.; Our machinery is composed of a dozen fast cutting off, suitable for aluminium, of many presses of various tonnage, of a dozen vertical cnc machining centres, of four traditional milling of various sizes, of various drills and threading machines.

Since 2002 TECNOAL is UNI EN ISO 9001:2008 certified and, conscious of the needs of customers and market, has planned substantial investments in production equipments.

Recently a large area of the factory has been dedicated to the welding adding to the traditional TIG line a new computerized welding line entirely automatic to grant a higher quality control to the manufacturing process, and to reduce production lead time and costs.

An important rationalization effort has been made in the CAM area with new machines directly interfaced with CAD and standardizing the CAD/CAM system to reduce the manufacturing and prototyping lead times.

Top priority is given by the TECNOAL management to the extend this policy to all other manufacturing areas.

The company employs 45 workers and technicians who follow all manufacturing activities from incoming raw materials (extruded aluminium bars) to shipment of final products to final customers.

All metal workings are made in Tecnoal with traditional or CNC machines (cutting, welding, drilling, threading, milling, assembling and washing) while surface finishing like black or coloured anodizing, painting, alodine, galvanizing, silver plating, etc... are made by external partners carefully selected and thoroughly controlled by TECNOAL Quality Control.

All our items are RoHS compliant.

Waiting for the opportunity to welcome You to our company and to present You our staff

Best regards

Managing Director

Paolo Poppi

*La validità del presente certificato è subordinata a sorveglianza periodica (ogni 6, 9 o 12 mesi) e al riesame completo del sistema con periodicità triennale*

*The validity of this certificate is subject to periodical audits (every 6, 9 or 12 months) and the complete re-assessment of the system every three years*

Le aziende in possesso di un certificato valido sono presenti nella banca dati sul sito [www.dnv.it](http://www.dnv.it) e sul sito Accredia ([www.accredia.it](http://www.accredia.it)) - All the companies with a valid certificate are online at the following addresses: [www.dnv.it](http://www.dnv.it) and [www.accredia.it](http://www.accredia.it)



Tecnoal company



Raw materials area



CNC machining area

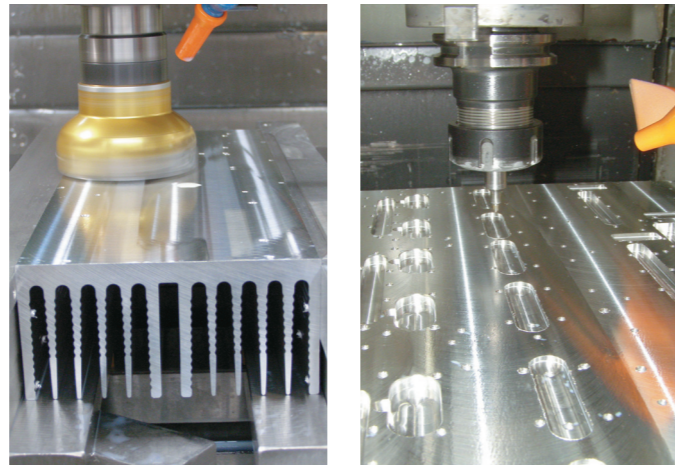

CNC machining



Items ready for working

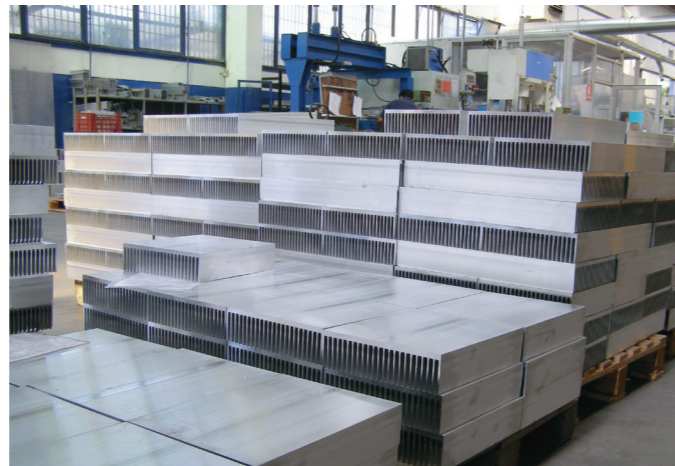

Items ready for working

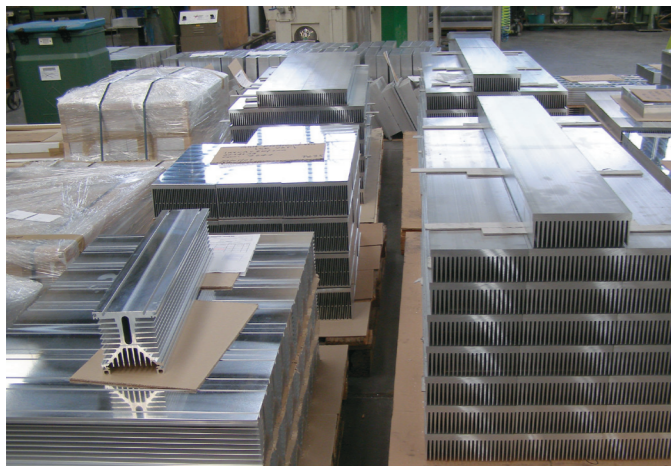

Packaging area



Shipment area

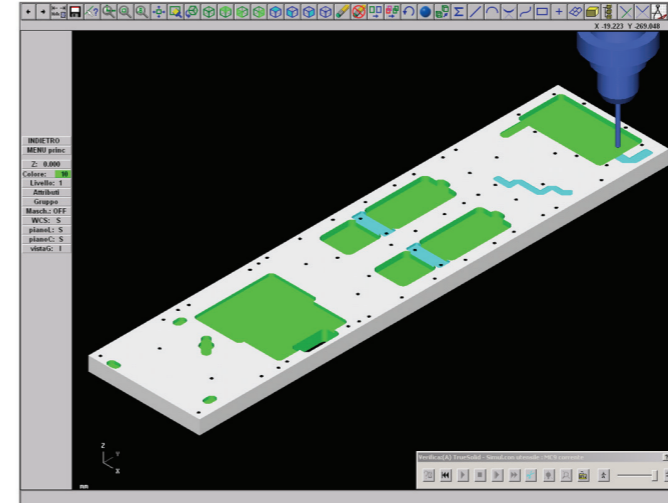

CNC machining simulation with CAD-CAM system

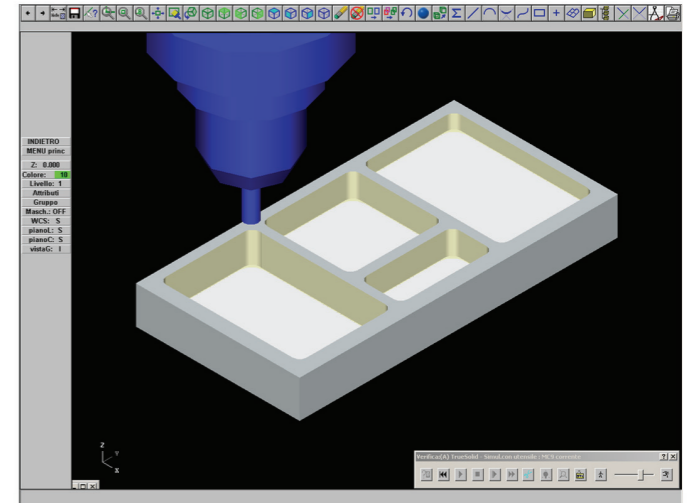

CNC machining simulation with CAD-CAM system

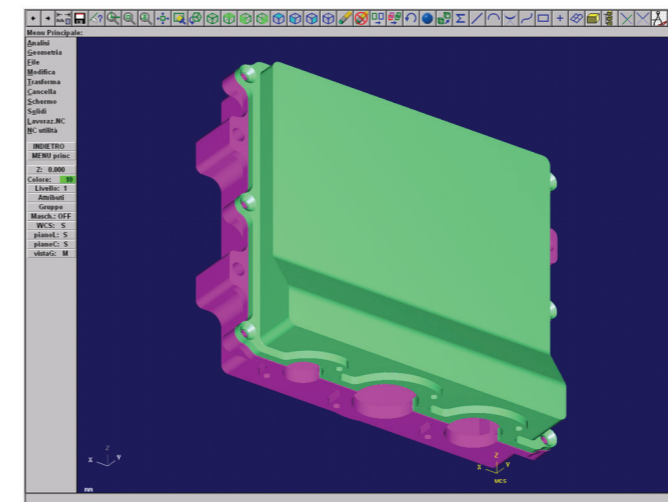

CNC machining simulation with CAD-CAM system

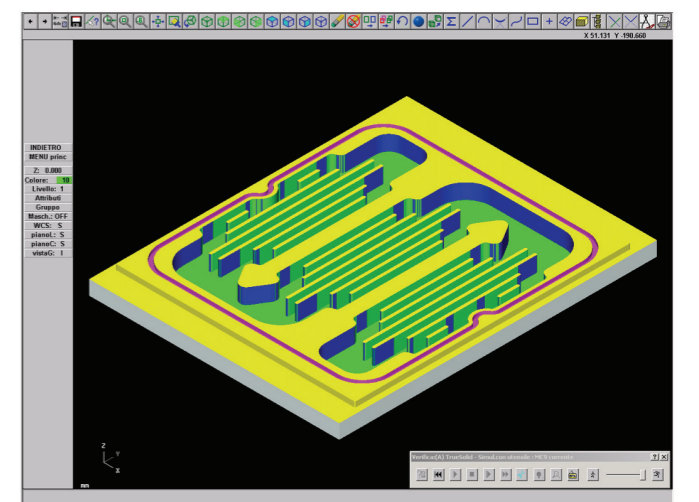

CNC machining simulation with CAD-CAM system

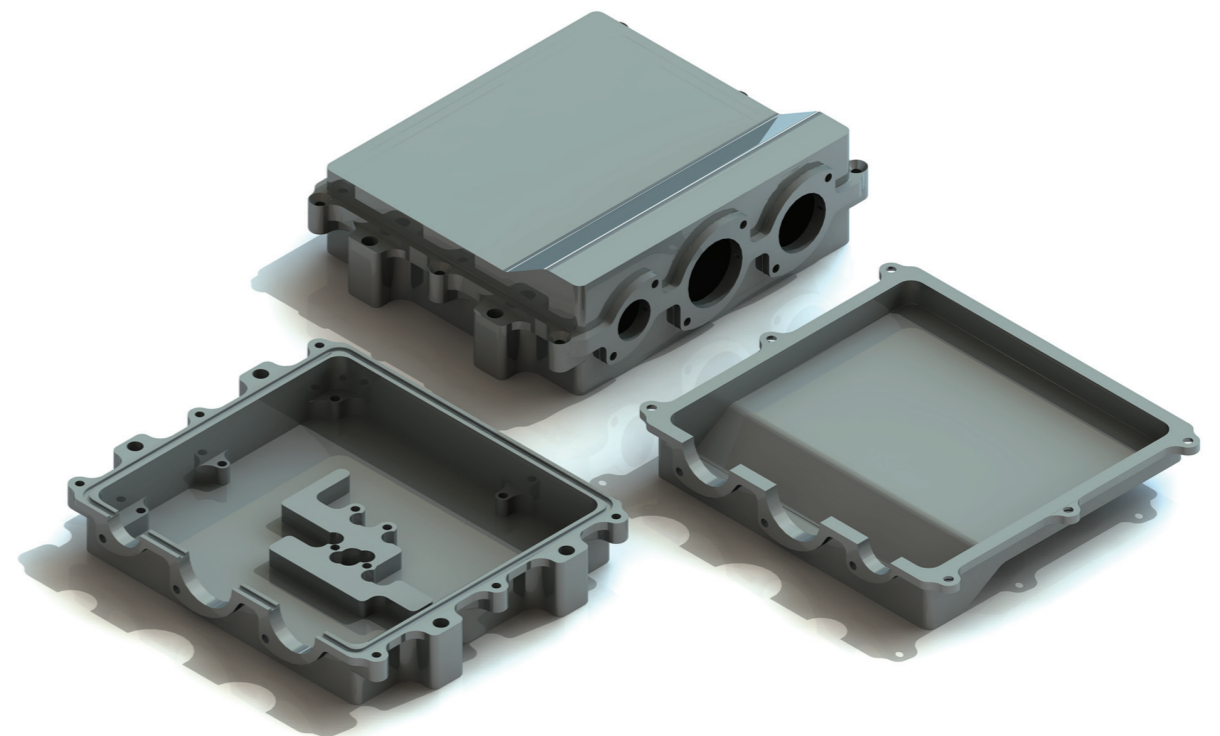



# INDICE INDEX

CERTIFICATO ISO 9001:2000	ISO 9001:2000 CERTIFICATE	II cop
PRESENTAZIONE	PRESENTATION	3
INDICE - PROFILI	INDEX - PROFILES	7
MATERIALI E DESIGNAZIONI	MATERIALS AND DESIGNATIONS	8
CARATTERISTICHE DEI MATERIALI - LEGA 6060	MATERIALS CHARACTERISTICS - ALLOY 6060	9
CARATTERISTICHE DEI MATERIALI - LEGA 6063	MATERIALS CHARACTERISTICS - ALLOY 6063	10
TOLLERANZE DI ESTRUSIONE	EXTRUSION TOLERANCES	11
TOLLERANZE DI LAVORAZIONE	MACHINING TOLERANCE	12
CONDIZIONI DI PROVA DEL LABORATORIO	LABORATORY TEST CONDITIONS	16
SPECIAL COOL PLATES	SPECIAL COOL PLATES	17
PROFILI INTEGRALI AD ALTA EFFICIENZA	HIGH EFFICIENCY INTEGRAL PROFILES	18
PROFILI MODULARI SERIE "T"	SERIES "T" MODULAR PROFILES	22
SISTEMA DI VENTILAZIONE	VENTILATION SYSTEM	24
CONDIZIONI DI PROVA	TEST'S STATE	24



# INDICE - PROFILI INDEX - PROFILES

PROFILI INTEGRALI AD ALTA EFFICIENZA IN VENTILAZIONE FORZATA HIGH EFFICIENCY INTEGRAL PROFILES			I 125FA - I 125MA		
	posiz. A	pag.		posiz. C	pag.
KA66	A	19	I 76EF	A	38
K72	B	19	I 77	B	38
K76	C	19	I 78	A	39
K91	D	19	I 80	B	39
KF126	A	20	I 80A	A	40
K133	B	20	I 80MF	B	40
K138	C	20	I 81	A	41
I150	D	20	I 84	B	41
KF163	A	21	I 84B	A	42
KF212	B	21	I 84C	B	42
KF215	C	21	I 84D	A	43
KF240	D	21	I 84G	B	43
			I 84M - I 84F	A	44
			I 84FA - I 84MA	B	44
			I 85B	C	44
			I 86E	A	45
			I 86ED	B	45
			I 90	A	46
			I 90M - I 90F	B	46
			I 91	A	47
			I 91A	B	47
			I 91MF	A	48
			I 93	B	48
			I 98T	A	49
			I 100A	B	49
			I 100CA	A	50
			I 105	B	50
			I 105A	A	51
			I 105B	B	51
			I 105C	A	52
			I 105M - I 105F	B	52
			I 117C	A	53
			I 117CA	B	53
			I 117F - I 117M	A	54
			I 117FA - I 117MA	B	54
			I 117MB	C	54
			I 125	A	55
			I 125A	B	55
			I 125B	A	56
			I 125C	B	56
			I 125D	A	57
			I 125P	B	57
			I 125Q	A	58
			I 125F - I 125M	B	58
			I 128	A	59
			I 128B	B	59
			I 128C	A	60
			I 128MF	B	60
			I 132	A	61
			I 132A	B	61
			I 137	A	62
			I 174	B	62
			I 210	A	63
			I 210MF	B	63
			I 125W1A	A	64
			I 125W2A	B	64
			I 125W3A	C	64
			I 125W4A	A	65
			I 125W5A	B	65
			I 125W6A	C	65
			I 125W7A	A	66
			I 125W8A	B	66
			I 125W9A	A	67
			I 125W10A	B	67
			I 125W11A	A	68
			I 125W1B	A	69
			I 125W3B	B	69
			I 125W3BA	A	70
			I 125W4B	B	70
			I 125W5B	C	70
			I 125W5BA	A	71
			I 125W6B	B	71
			I 125W7B	A	72
			I 125W8B	B	72
			I 125W9B	A	73
			I 125W10B	B	73
			I 125W11B	A	74
			I 125W1C	A	75
			I 125W2C	B	75
			I 125W3C	A	76
			I 125W4C	B	76
			I 125W5C	A	77
			I 125W7C	B	77
			I 125W9C	A	78
			I 125W11C	B	78

# MATERIALI E DESIGNAZIONI MATERIALS AND DESIGNATIONS

## ALLUMINIO

### CARATTERISTICHE MATERIALE

Tutti i profili presenti in questo catalogo, salvo diversa indicazione, sono estrusi in lega di alluminio EN AW-6060  
Designazione numerica 6060 al Mg Si 0.5 (a richiesta su alcuni profili lega EN-AW 6063 Designazione numerica 6063)  
Stato fisico T5  
Peso specifico Kg/dm<sup>3</sup> 2.7

### TOLLERANZE DI ESTRUSIONE

Tutti i profili sono estrusi nel rispetto delle norme UNI EN 755/9. Per esigenze specifiche e per dissipatori realizzati su disegno si possono ottenere tolleranze di estrusione fino al 50% delle norme UNI EN 755/9.  
Qualora vi siano delle dimensioni critiche, che devono essere rispettate, queste devono essere concordate preventivamente.

### TRATTAMENTI E FINITURE SUPERFICIALI

TRATTAMENTI SUPERFICIALI
Anodizzazione (nera, naturale, oro e colorata) Decapaggio (sgrassaggio - sbiancatura) Cromatazione (alodyne 1000 bianco) Nichelatura Cromatura Argentatura Verniciatura Serigrafia, ecc

FINITURE SUPERFICIALI
Burattatura Sabbatura - pallinatura Satinatura Spazzolatura meccanica, ecc.

Specificare chiaramente se sono richieste esigenze estetiche.

## RAME

### CARATTERISTICHE MATERIALE

Composizione materiale: secondo UNI 5649-71  
Rame elettrolitico CU-ETP 99.9 %

### TRATTAMENTI E FINITURE SUPERFICIALI

TRATTAMENTI SUPERFICIALI
Stagnatura Argentatura Nichelatura Zincatura (nera)

FINITURE SUPERFICIALI
Satinatura Spazzolatura meccanica

## ALUMINIUM

### MATERIAL CHARACTERISTICS

Unless otherwise specified, all profiles in this catalogue are extruded in aluminium alloy EN AW-6060  
Numerical designation 6060 at Mg Si 0.5 (upon request on some alloy EN-AW 6063 Designazione numerica 6063)  
Physical state T5  
Specific weight Kg/dm<sup>3</sup> 2.7

### EXTRUSION TOLERANCE

All profiles are extruded in compliance with UNI EN 755/9 regulations. For specific needs and for heat sinks made to order it is possible to obtain extrusion tolerances up to 50% of the UNI EN 755/9 regulation.  
Whenever there are critical dimensions that must be respected, they must be agreed in advance.

### SURFACE TREATMENTS AND FINISHES

SURFACE TREATMENTS
Anodization (black, natural, gold and colored) Pickling (degreasing - bleaching) Chromatizing (Alodyne 1000 white) Nickel-plating Chromium plating Silver-plating Painting Silk-screening, etc.

SURFACE FINISHES
Barrel finishing Abrasive blasting - shot peening Silking Mechanical brushing, etc.

Clearly specify if there are esthetic requirements.

## COPPER

### MATERIAL CHARACTERISTICS

Material composition: according to UNI 5649-71  
Electrolytic copper CU-ETP 99.9 %

### SURFACE TREATMENTS AND FINISHES

SURFACE TREATMENTS
Tinning Silver-plating Nickel-plating Galvanizing (black)

SURFACE FINISHES
Silking Mechanical brushing

# CARATTERISTICHE DEI MATERIALI MATERIALS CHARACTERISTICS

## LEGA 6060 - ALLOY 6060

LEGA ALLUMINIO - MAGNESIO - SILICIO PRIMARIA DA LAVORAZIONE  
Designazione convenzionale della lega: EN AW - 6060 UNI 573-3  
Designazione numerica: 6060  
Applicazione tipiche: estrusi a disegno e sistemi

PRIMARY ALUMINIUM - MAGNESIUM - SILICON ALLOY FOR ALLOY FORGING  
Conventional alloy designation: EN AW - 6060 UNI 573-3  
Numerical designation: 6060  
Typical applications: design and systems extrusion

COMPOSIZIONE CHIMICA IN PESO %					CHEMICAL COMPOSITION IN WEIGHT %					
LEGA	ALLOY	Cu	Fe	Mn	Mg	Zn	Si	Impurità	Impurity	Al
6060		0,10	0,10 - 0,30	0,10	0,10 - 0,30	0,10	0,30 - 0,60	0,05 - 0,15		Resto Remaining

ESTRUSI PROPRIETA' FISICHE TIPICHE				TYPICAL PHYSICAL PROPERTIES OF EXTRUSION			
LEGA	Stato fisico	Densità	Resistenza elettrica	Conducibilità termica	intervallo di fusione	coefficiente dilatazione termica	Modulo elasticità
ALLOY	Physical state	Density	Electrical resistance	Thermal conductivity	Melting range	Thermal expansion coefficient	Elasticity coefficient
	*	Kg/dm <sup>3</sup>	Ohm mm <sup>2</sup> mm	W/mk	°C	20-100 °C x 10 <sup>-6</sup> /°C	N/mm <sup>2</sup>
6060	T1 T5 T6	2,70	0,034 0,031 0,033	193 209 201	615 - 655	23	69000

ESTRUSI PROPRIETA' MECCANICHE TIPICHE				MECHANICAL PROPERTIES OF TYPICAL EXTRUSION		
LEGA	Stato fisico	Carico unitario di rottura a trazione Stato fisico	Carico unitario di scostamento della proporzionalità	Allungamento	Durezza Brinnell	
ALLOY	Physical state	Tensile strength at break	Unit load of deviation from proportionality	Elongation	Brinnell hardness	
	*	Rm N/mm <sup>2</sup>	Rm0.2 N/mm <sup>2</sup>	A %	HB	
6060	0 F T1 T5 T6	140 100 125 185 205	80 70 145 165	22 18 16 15	40 45 60 70	

CARATTERISTICHE TECNOLOGICHE (INDICATIVE)				TECHNOLOGICAL CHARACTERISTICS (INDICATIVE)								
Stato fisico	Deformabilità plastica a freddo	Lavorabilità all' utensile	Resistenza alla corrosione atmosferica	Resistenza alla corrosione marina	Anodizzazione	Saldabilità						
Physical state	Plastic deformability cold	Tool machinability	Resistance to atmospheric corrosion	Resistance to marine corrosion	Anodization	Weldability						
T1 T5 T6	Buona Buona Sufficiente	Good Good Sufficient	Sconsigliabile Buona Buona	Not advisable Good Good	Ottima Ottima Ottima	Excellent Excellent Excellent	Buona Buona Buona	Good Good Good	Ottima Ottima Ottima	Excellent Excellent Excellent	Ottima Ottima Ottima	Excellent Excellent Excellent

\* STATO FISICO  
0 Grezzo di estrusione  
F Ricotto  
T1 Raffreddato al termine di un processo di lavorazione plastica ad elevata temperatura ed invecchiamento naturale  
T5 Raffreddato al termine di un processo di lavorazione plastica ad elevata temperatura ed invecchiamento artificiale  
T6 Solubilizzato, temperato e invecchiato artificialmente

\* PHYSICAL STATE  
0 Extrusion blank  
F Annealed  
T1 Cooled subsequent to high temperature plastic forging and natural ageing  
T5 Cooled subsequent to high temperature plastic forging and artificial ageing  
T6 Solubilized, tempered and artificially aged

# CARATTERISTICHE DEI MATERIALI MATERIALS CHARACTERISTICS

## LEGA 6063 - ALLOY 6063

LEGA ALLUMINIO - MAGNESIO - SILICIO PRIMARIA DA LAVORAZIONE  
Designazione convenzionale della lega: EN AW - 6063 UNI 573-3  
Designazione numerica: 6063  
Applicazione tipiche: estrusi a disegno e sistemi

PRIMARY ALUMINIUM - MAGNESIUM - SILICON ALLOY FOR ALLOY FORGING  
Conventional alloy designation: EN AW - 6063 UNI 573-3  
Numerical designation: 6063  
Typical applications: design and systems extrusion

### COMPOSIZIONE CHIMICA IN PESO % CHEMICAL COMPOSITION IN WEIGHT %

LEGA	ALLOY	Cu	Fe	Mn	Mg	Zn	Si	Impurità	Impurity	Al
6063		0,10	0,35	0,10	0,45 - 0,90	0,10	0,40 - 0,60	0,05 - 0,15	Resto	Remaining

### ESTRUSI PROPRIETA' FISICHE TIPICHE TYPICAL PHYSICAL PROPERTIES OF EXTRUSION

LEGA	Stato fisico	Densità	Resistenza elettrica	Conducibilità termica	intervallo di fusione	coefficiente dilatazione termica	Modulo elasticità
ALLOY	Physical state	Density	Electrical resistance	Thermal conductivity	Melting range	Thermal expansion coefficient	Elasticity coefficient
6063	T6	2,70	0,033	201	615 - 655	23	69000

### ESTRUSI PROPRIETA' MECCANICHE TIPICHE MECHANICAL PROPERTIES OF TYPICAL EXTRUSION

LEGA	Stato fisico	Carico unitario di rottura a trazione	Carico unitario di scostamento della proporzionalità	Allungamento	Durezza Brinnell
ALLOY	Physical state	Tensile strength at break	Unit load of deviation from proportionality	Elongation	Brinnell hardness
6063	T6	245	195	9	80

### CARATTERISTICHE TECNOLOGICHE (INDICATIVE) TECHNOLOGICAL CHARACTERISTICS (INDICATIVE)

Stato fisico	Deformabilità plastica a freddo	Lavorabilità all' utensile	Resistenza alla corrosione atmosferica	Resistenza alla corrosione marina	Anodizzazione	Saldabilità
Physical state	Plastic deformability cold	Tool machinability	Resistance to atmospheric corrosion	Resistance to marine corrosion	Anodization	Weldability
T6	Sufficiente	Buona	Ottima	Buona	Ottima	Ottima

\* STATO FISICO  
T6 Tempra in acqua seguita da invecchiamento artificiale

\* PHYSICAL STATE  
T6 Tempered in water followed by artificial ageing

# TOLLERANZE DI ESTRUSIONE ESTRATTE DA UNI EN 755/9 EXTRUSION TOLERANCES FROM UNI EN 755/9

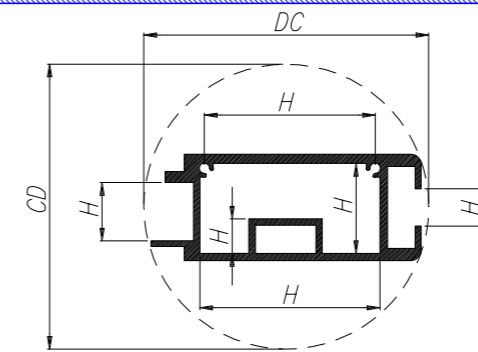

### TOLLERANZE DIMENSIONALI - DIMENSION TOLERANCE

Dimensione	Tolleranza su H per diametro circoscritto DC (mm)	Tolleranza su H per diametro circoscritto DC (mm)	Tolleranza su H per diametro circoscritto DC (mm)	Tolleranza su H per diametro circoscritto DC (mm)	
Dimension	H Tolerance by circumscribed diameter DC (mm)	H Tolerance by circumscribed diameter DC (mm)	H Tolerance by circumscribed diameter DC (mm)	H Tolerance by circumscribed diameter DC (mm)	
Maggiore di	Minore o uguale a	≤ 100	> 100 & ≤ 200	> 200 & ≤ 300	> 300 & ≤ 500
Greater of	Minor or equal to	± 0.25	± 0.30	± 0.35	± 0.40
10	25	± 0.30	± 0.40	± 0.50	± 0.60
25	50	± 0.50	± 0.60	± 1.80	± 0.90
50	100	± 0.70	± 0.90	± 1.10	± 1.30
100	150	--	± 1.10	± 1.30	± 1.50
150	200	--	± 1.30	± 1.50	± 1.80
200	300	--	--	± 1.70	± 2.10
300	450	--	--	--	± 2.80

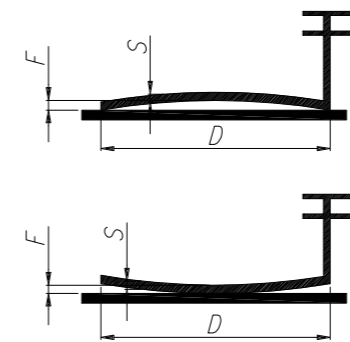

(\*) Se il profilato ha spessore variabile nell'aggruppamento di misurazione, deve essere usato il più sottile  
(\*) Select minor thickness

### TOLLERANZE DI CONVESSITA' E CONCAVITA' CONVEXITY AND CONCAVITY TOLERANCES

Larghezza	Scostamento F (mm)	Deviation F (mm)	Scostamento F (mm)	Deviation F (mm)
Width	Profiled hollow (*) - Hollow profile (*)	Profiled hollow (*) - Hollow profile (*)	Profiled hollow (*) - Hollow profile (*)	Profiled hollow (*) - Hollow profile (*)
Maggiore di	Minore o uguale a	Spessore Thickness	Spessore Thickness	Spessore Thickness
Greater of	Minor or equal to	S ≤ 5	S > 5	S > 5
--	30	0.30	0.20	0.20
30	60	0.40	0.30	0.30
60	100	0.60	0.40	0.40
100	150	0.90	0.60	0.60
150	200	1.20	0.80	0.80
200	300	1.80	1.20	1.20
300	400	2.40	1.60	1.60

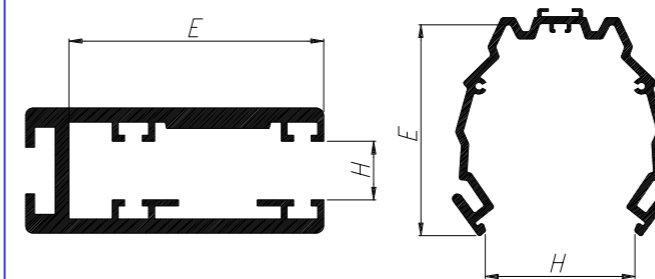

### TOLLERANZE DI APERTURA - APERTURE TOLERANCES

Dimensione	Tolleranza su H in aggiunta a quella dimensionale per sezioni con estremità aperte	Dimensione	Tolleranza su H in aggiunta a quella dimensionale per sezioni con estremità aperte
Dimension	For open ends to dimension H add this tolerance	Dimension	For open ends to dimension H add this tolerance
Maggiore di	Minore o uguale a	Maggiore di	Minore o uguale a
Greater of	Minor or equal to	Greater of	Minor or equal to
--	20	100	125
20	30	± 0.15	150
30	40	± 0.25	180
40	60	± 0.40	210
60	80	± 0.50	250
80	100	± 0.60	250
			± 1.80

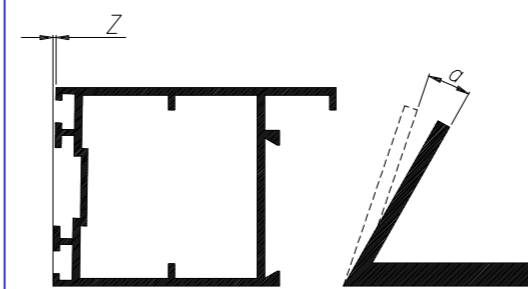

Lo scostamento massimo consentito per un angolo diverso dall'angolo retto deve essere ±1°  
Maximum deviation allowed for not right angle must be ±1°

### TOLLERANZE DI ANGOLARITA' - ANGULARITY TOLERANCE

Larghezza	Scostamento massimo consentito Z dall'angolo retto
Width	Maximum deviation Z from right angle
Maggiore di	Minore o uguale a
Greater of	Minor or equal to
--	30
30	50
50	80
80	120
120	180
180	240
240	300
300	400

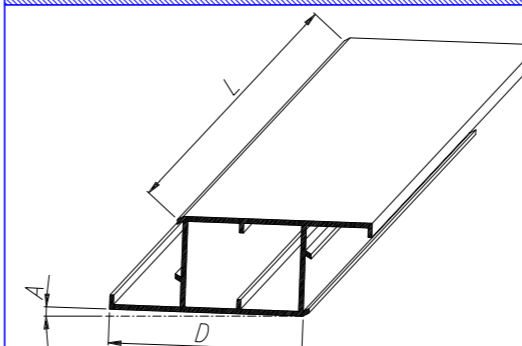

### TOLLERANZE DI TORSIONE - TORSION TOLERANCE

Larghezza	Tolleranza di torsione A sulla lunghezza L
Width	Torsion tolerance A for length L
Maggiore di	Minore o uguale a
Greater of	Minor or equal to
--	20
30	50
50	100
100	200
200	300
300	450

(\*) Per lunghezze inferiori a 1000mm tolleranze da concordare  
(\*) Tolerance to define for length minor than 1000mm

nella realtà il dissipatore andrà ad operare in condizioni sicuramente peggiori di quelle presenti al momento della prova di laboratorio. Un esempio molto semplice per chiarire il concetto se la potenza totale da dissipare è di 35W e imponiamo che il dispositivo possa arrivare alla temperatura massima di 80°C con una temperatura ambiente di 30°C utilizzeremo la semplice formula:

$$RT = \frac{\Delta T}{W}$$

Dove:

RT = resistenza termica del dissipatore  
 $\Delta T$  = temperatura massima del dissipatore meno temperatura ambiente  
 W = potenza massima dissipata

Sostituendo i valori del progetto nella formula abbiamo:

$$\Delta T = 80 - 30 = 50 \text{ }^\circ\text{C}$$

$$W = 35 \text{ W}$$

Questo dato, ancora teorico, andrà diminuito leggermente per renderlo realmente applicabile al progetto. Si può partire da 1,1 ÷ 1,3 °C/W.

A questo punto i dati riportati sul catalogo ci consentono ampi margini di scelta trattandosi di individuare fra tanti profili di media potenza il più adatto per dimensioni e facilità di montaggio al nostro utilizzo.

Difficilmente si troverà il valore della RT cercata direttamente sulle tabelle, essendo i valori riportati relativi a lunghezze predeterminate; come è intuitivo occorrerà allungare o accorciare il profilo per diminuire o aumentare la RT.

**ATTENZIONE!**

Trattandosi di conduzione termica il valore della RT non cambia con legge lineare, ovvero: raddoppiando la lunghezza di un dissipatore non si dimezza la sua resistenza termica! Va inoltre tenuto conto che la disposizione del carico termico influenza in modo determinante l'efficienza del dissipatore.

**VENTILAZIONE FORZATA**

Nel caso che il dispositivo da progettare preveda la ventilazione forzata, è ancora possibile utilizzare i dati del catalogo tenendo presente che la RT rilevata in ventilazione naturale diminuisce proporzionalmente all'aumento della velocità dell'aria. In tabella 1 è riportato l'andamento puramente teorico di tale diminuzione.

È pure possibile valutare in modo molto approssimato come diminuisce la RT all'aumentare della lunghezza del dissipatore. Riportiamo in tabella 2 un tipico andamento.

will be subject to worse conditions than those used in laboratory testing. A very simple example to clarify the concept: if the total power to dissipate is 35W and we determine that the device can reach a maximum temperature of 80°C with an ambient temperature of 30°C, we can use the following formula:

$$TR = \frac{\Delta T}{W}$$

Where:

TR = thermal resistance of the heat sink  
 $\Delta T$  = maximum temperature of the heat sink minus ambient temperature  
 W = maximum dissipated power

Substituting the project values in the formula we have:

$$\Delta T = 80 - 30 = 50 \text{ }^\circ\text{C}$$

$$W = 35 \text{ W}$$

This theoretical result will be slightly reduced to make it more realistically applicable to the project. A starting point would be from 1.1 – 1.3 °C/W.

At this point the data indicated in the catalogue allow us a wide range of choice in identifying among many profiles of medium power the most suitable in terms of dimensions and ease of installation for our use.

It is unlikely to find the desired TR value directly in the tables as these indicated values regard predetermined lengths. As is evident, it is necessary to lengthen or shorten the profile to decrease or increase the TR.

**CAUTION!**

Since thermal conduction is involved the TR value does not change on a linear basis. For example, doubling the length of the heat sink will not reduce its thermal resistance by one half! It is also important to bear in mind that the thermal load disposition has a determining effect on the effectiveness of the heat sink.

**FORCED VENTILATION**

When the design involves the use of forced ventilation it is still possible to use the catalogue data, bearing in mind that the TR measured in natural ventilation decreases proportionally with the air velocity. Table 1 shows the purely theoretical trend of this decrease.

It is possible to approximately evaluate the decrease in TR with the increase in heat sink length. Table 2 shows a typical trend.

**ATTENZIONE!**

Tutti i fattori di non linearità che caratterizzano la conduzione termica sono enormemente amplificati in caso di ventilazione forzata. Bisogna infatti mettere in conto che la geometria del profilo, il tipo di ventilatore, la presenza o meno di un convogliatore, l'insorgenza o meno di vortici, la disposizione dei carichi termici, ecc. interagiscono contemporaneamente in modo talmente imprevedibile da rendere praticamente improntabile un dispositivo.

In questi casi solo la conoscenza, l'esperienza e le prove di laboratorio possono aiutare il progettista.

E' in effetti in questo contesto che la TECNOAL mette a completa disposizione il proprio laboratorio per risolvere rapidamente e nel modo migliore i problemi dei clienti.

**IMPORTANTE**

I dati e le informazioni riportate sul presente catalogo sono stati rilevati in modo accurato e pertanto affidabili. Al cliente rimane comunque la responsabilità di verificare la correttezza dell'uso finale dei dispositivi.

La TECNOAL non potendo essere a conoscenza dell'uso specifico che ne sarà fatto non può essere ritenuta responsabile in alcun modo per eventuali incidenti o danni provocati durante l'impiego dei suoi prodotti.

Si riserva altresì il diritto di apportare senza preavviso qualsiasi variazione ai propri prodotti, allo scopo di migliorarne la qualità e l'efficienza.

Tutti i profili estrusi in alluminio sono soggetti alle norme di tolleranza sull'estrusione UNI EN 755/9; di conseguenza i pesi riportati sono valori medi teorici e oscillano all'interno dei campi di tolleranze dimensionali.

**CAUTION!**

All non-linear factors that characterize thermal conduction are greatly amplified with forced ventilation. It is necessary to consider that geometric properties of the profile, the type of fan, the presence (or lack) of a conveyor, the possibility of vortexes, the disposition of thermal loads, etc. simultaneously interact in such an unpredictable way that make device design nearly impossible. In these cases only knowledge, experience and laboratory testing can help the designer. It is exactly in these situations that TECNOAL makes it laboratory available to quickly resolve client problems with the best solutions.

**IMPORTANT**

The data and information contained in this catalogue have been carefully compiled and are therefore reliable. However, the client still has the responsibility of ensuring the correct use of the devices. TECNOAL cannot know the specific use of its products and therefore cannot be held responsible in any way for any incidents or damage caused during the use of such products. The company also reserves the right to modify its products without prior notice in order to improve their quality and efficiency. All extruded aluminium profiles are subject to UNI EN 755/9 regulations regarding extrusion tolerance. Consequently, the indicated weights are theoretical average values and vary within the range of dimension tolerances.



tabella 1 / table 1



tabella 2 / table 2

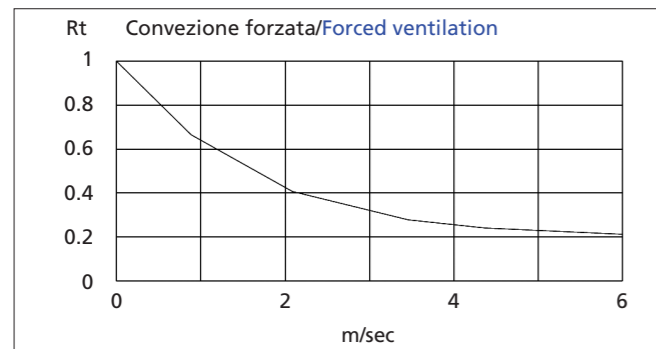

Prova di laboratorio/Laboratory: test heatsink

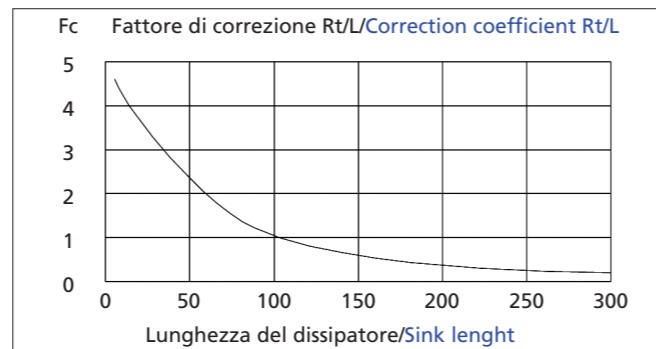
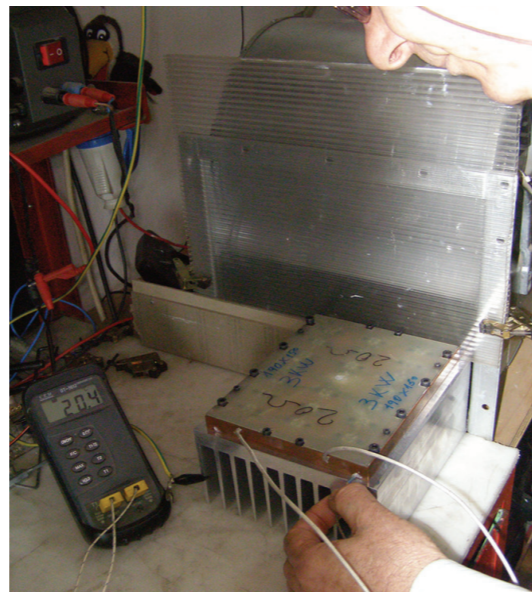
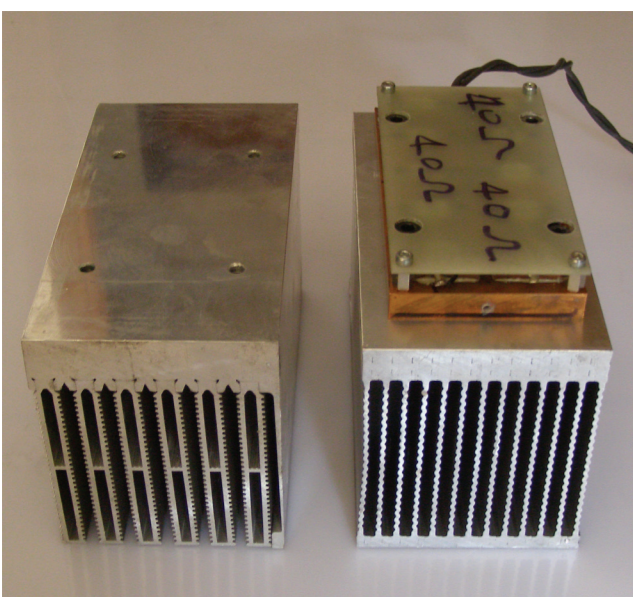

Test di comparazione/Laboratory comparison test



Strumentazione di laboratorio/Laboratory equipment

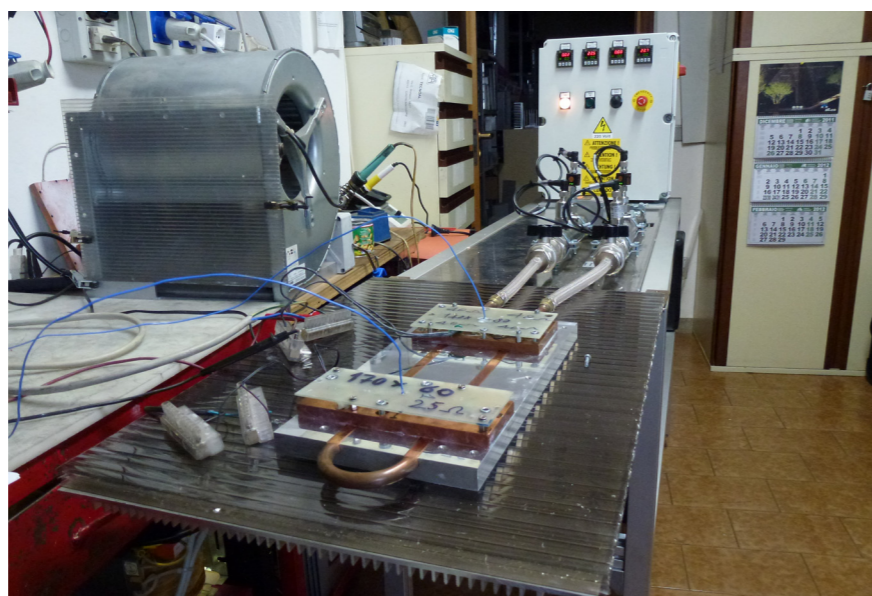

Banco di prova per dissipatori ad acqua  
Equipment test for fluid cooler heatsinks

## TOLLERANZE DI LAVORAZIONE MACHINING TOLERANCE

Tecnoal ha adottato come tolleranze usuali per le lavorazioni meccaniche ove non diversamente specificato

- taglio + 0 - 0,5
- riferimenti  $\pm 0,3$
- interassi  $\pm 0,2$  (non cumulabile)
- profondità filettature 2 volte il diametro più un millimetro.

Altre lavorazioni ove non specificato grado di precisione medio secondo UNI 22768-1-m

Unless otherwise indicated, Tecnoal has machining tolerances as follows:

- cut + 0 - 0,5
- reference  $\pm 0,3$
- distances between centers  $\pm 0,2$  (non combinable)
- thread depths 2 times the diameter plus one millimeter.

Other machining where average degree of precision not specified according to UNI 22768-1-m

Classe di tolleranza/Tolerance class		(*)							
Designazione Designation	Denominazione Denomination	da/from 0,5 fino a/to 3	oltre/over 3 fino a/to 6	oltre/over 6 fino a/to 30	oltre/over 30 fino a/to 120	oltre/over 120 fino a/to 400	oltre/over 400 fino a/to 1000	oltre/over 1000 fino a/to 2000	oltre/over 2000 fino a/to 4000
f	Fine/Thin	$\pm 0.05$	$\pm 0.05$	$\pm 0.1$	$\pm 0.15$	$\pm 0.2$	$\pm 0.3$	$\pm 0.5$	—
m	Media/Medium	$\pm 0.1$	$\pm 0.1$	$\pm 0.2$	$\pm 0.3$	$\pm 0.5$	$\pm 0.8$	$\pm 1.2$	$\pm 2$
c	Grossolana/Thick	$\pm 0.2$	$\pm 0.3$	$\pm 0.5$	$\pm 0.8$	$\pm 1.2$	$\pm 2$	$\pm 3$	$\pm 4$
v	Molto grossolana/Very thick	—	$\pm 0.5$	$\pm 1$	$\pm 1.5$	$\pm 2.5$	$\pm 4$	$\pm 6$	$\pm 8$

Classe di tolleranza applicata  
Applied tolerance class

(\*) Per dimensioni nominali minori di 0,5 mm., gli scostamenti devono essere indicati vicino alla dimensione nominali relativa  
(\*) For nominal dimensions less than 0.5 mm, the deviation must be indicated near the relative nominal dimension.

### CRITERI DI ACCETTAZIONE (UNI EN 22768-1)

Salvo indicazione contraria, i pezzi non conformi alle tolleranze generali prescritte non devono essere automaticamente rifiutati quando la funzionalità del pezzo non risulta compromessa.

### ACCEPTANCE CRITERIA (UNI EN 22768-1)

Unless otherwise indicated, pieces not in compliance with the general prescribed tolerances should not automatically be refused when the functionality of the piece has not been compromised.

## NOTE TECNICHE

Il presente catalogo è stato elaborato dal settore tecnico-commerciale della TECNOAL allo scopo di fornire al progettista elettronico un valido aiuto nella scelta del dissipatore più adatto ad uno specifico impiego. I dati di resistenza termica (RT) riferiti ad un provino di data lunghezza L riportati nella tabella di ogni profilo sono dati sperimentali riferiti a risultati di prove di laboratorio.

Le condizioni di prova sono quelle che garantiscono il massimo rendimento del dissipatore, ovvero:

- 1) ventilazione naturale;
- 2) carico termico applicato su tutta la superficie caricabile;
- 3) posizione "verticale" per sfruttare il massimo "dell'effetto camino" sul flusso dell'aria;
- 4) superficie opaca ossidata nera per favorire lo scambio termico anche per irraggiamento;
- 5) nessun corpo nelle vicinanze del dissipatore in prova per minimizzare le perturbazioni ambientali;
- 6) temperatura rilevata tramite termocoppia all'interno del dissipatore immediatamente sotto il carico in zona centrale del provino.

I valori riportati sul catalogo fanno riferimento ad un RT rilevata con una differenza di temperatura dissipatore-ambiente  $\Delta T = 60^\circ C$ .

Questo è in effetti il carico massimo di utilizzo per la maggioranza dei dispositivi a stato solido. La logica conseguenza di quanto sopra esposto è che per il progettista i valori della RT riportati in catalogo sono solo una buona base di partenza per scegliere il dissipatore più adatto al proprio impiego per arrivare al risultato definitivo occorre tenere conto che

## TECHNICAL NOTES

This catalogue has been prepared by TECNOAL's design marketing department in order to provide electronic design engineers with the means to choose the most suitable heat sink for a given use.

The data regarding thermal resistance (TR) relative to a test piece of a given length L indicated in the table of each profile are experimental data gleaned from the results of laboratory experiments.

The test conditions are those which guarantee maximum performance by the heat sink, and include:

- 1) natural ventilation
- 2) thermal load applied to the entire load surface
- 3) vertical position to take maximum advantage of the chimney effect on airflow
- 4) anodized black opaque surface to enhance thermal exchange through heat radiation as well
- 5) absence of objects near the tested heat sink to minimize environmental disturbances
- 6) temperature measured by means of a thermocouple inside the heat sink immediately below the load in the center area of the test piece.

The values indicated in the catalogue refer to a TR detected with a heat sink-ambient temperature difference of  $\Delta T = 60^\circ C$ . This is effectively the maximum load for usage of the majority of solid layer devices. The logical consequence of the above is that the designer should use the TR values reported in the catalogue only as a starting point in selecting the most suitable heat sink for a given use. In order to reach a definitive result it is necessary to be aware that in reality the heat sink



# CONDIZIONI DI PROVA DEL LABORATORIO LABORATORY TEST CONDITIONS

La scelta del profilo più adatto ad uno specifico progetto è quasi sempre un'impresa molto ardua perché i dati del dissipatore che vengono riportati sui cataloghi sono solo teorici. Pertanto soprattutto nel caso della ventilazione forzata sono di difficile utilizzo a causa della complessa interdipendenza fra le reali condizioni di ventilazione, la disposizione dei carichi e la esigenza sempre più pressante di miniaturizzazione e di bassi costi. Partendo da queste considerazioni TECNOAL ha messo a punto un nuovo tipo di carico termico che simula perfettamente l'architettura e le dimensioni dei nuovi moduli di potenza IGBT. In questa maniera durante le prove di laboratorio è possibile rilevare con grande precisione la reale temperatura di lavoro a cui sono sottoposte le varie zone del modulo in prova e i relativi gradienti. Naturalmente sarà compito del cliente fornire ai tecnici del laboratorio della Tecnoal i dati più esatti possibili sulle esigenze del progetto (dimensioni del profilo, carico termico, condizioni di ventilazione, carico continuo o variabile ecc...).

I dati rilevati da Tecnoal nelle prove di laboratorio sono affidabili ed esatti. Il grado di precisione lo possiamo collocare in un campo di tolleranza di  $\pm 5\%$ . È opportuno comunque che il cliente ne verifichi l'applicabilità al suo progetto che può differire in modo sostanziale dalle condizioni di prova. Precisiamo inoltre che Tecnoal non può quindi essere ritenuta responsabile per incidenti o danni che si dovessero verificare durante l'uso dei suoi prodotti.

Choosing the most appropriate profile for a specific project can be a very difficult undertaking because the heatsinks data reported in the catalogues are only theoretical. Therefore especially in case of forced ventilation it's very difficult to use them due to the complex interdependence between the real condition of ventilation, the layout of loads and the more strong need of miniaturization and low costs. From these considerations TECNOAL has developed a new type of thermal load that perfectly simulates the architecture and the size of the new IGBT power modules. In this way during the laboratory tests it is possible to detect with great accuracy the real working temperature of the different parts of the module under test and their gradients. Of course the costumers should provide Tecnoal labs with the most accurate data regarding the project requirements (profile size, thermal load, ventilation conditions, continues or variable load etc...)

The data obtained in laboratory tests are reliable and exacts. The precision grade we can place in a field of  $\pm 5\%$ . Customer need to verify if condition test are similar to his project. So Tecnoal has no responsibility during the use of his items.

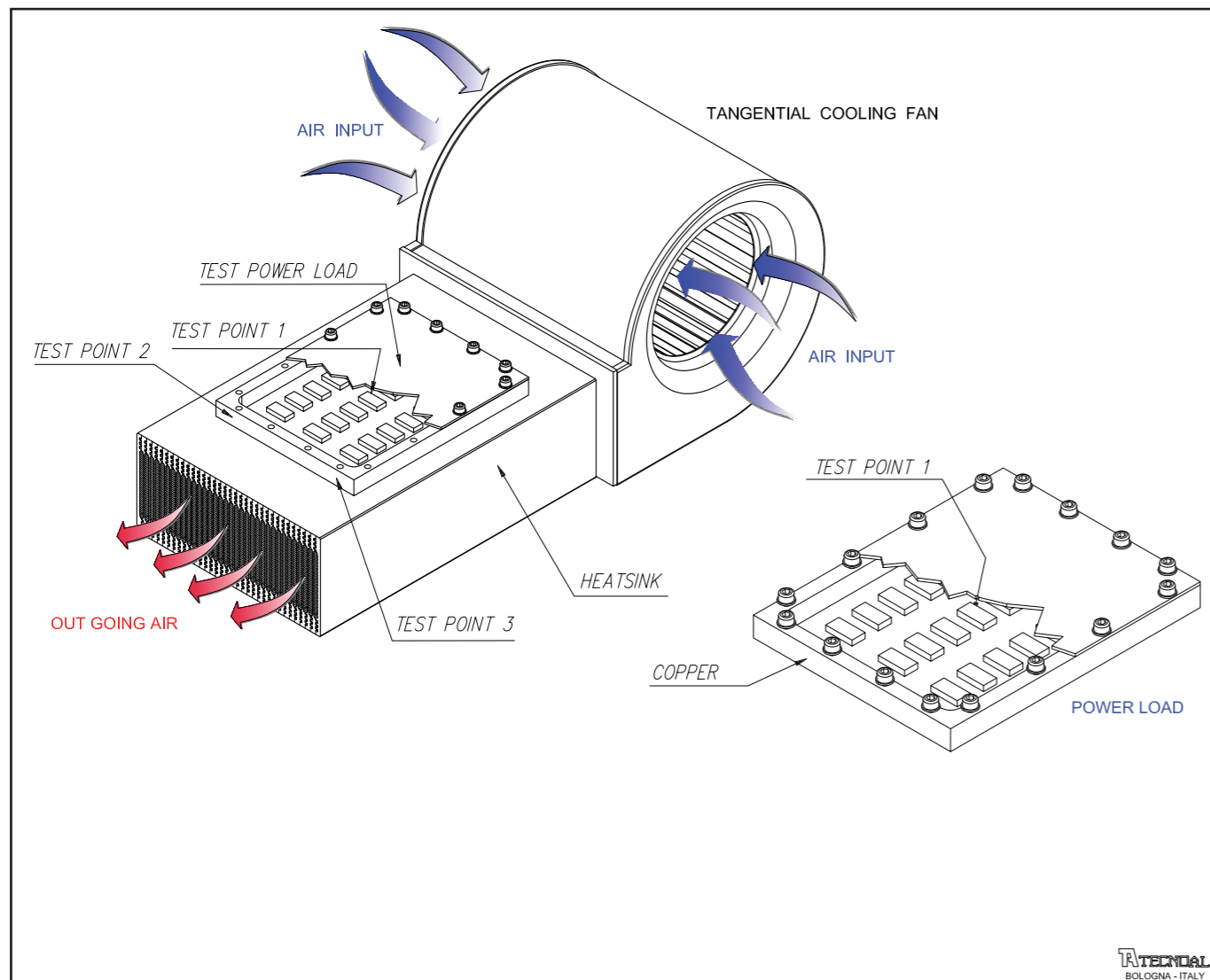

# SPECIAL COOL PLATES

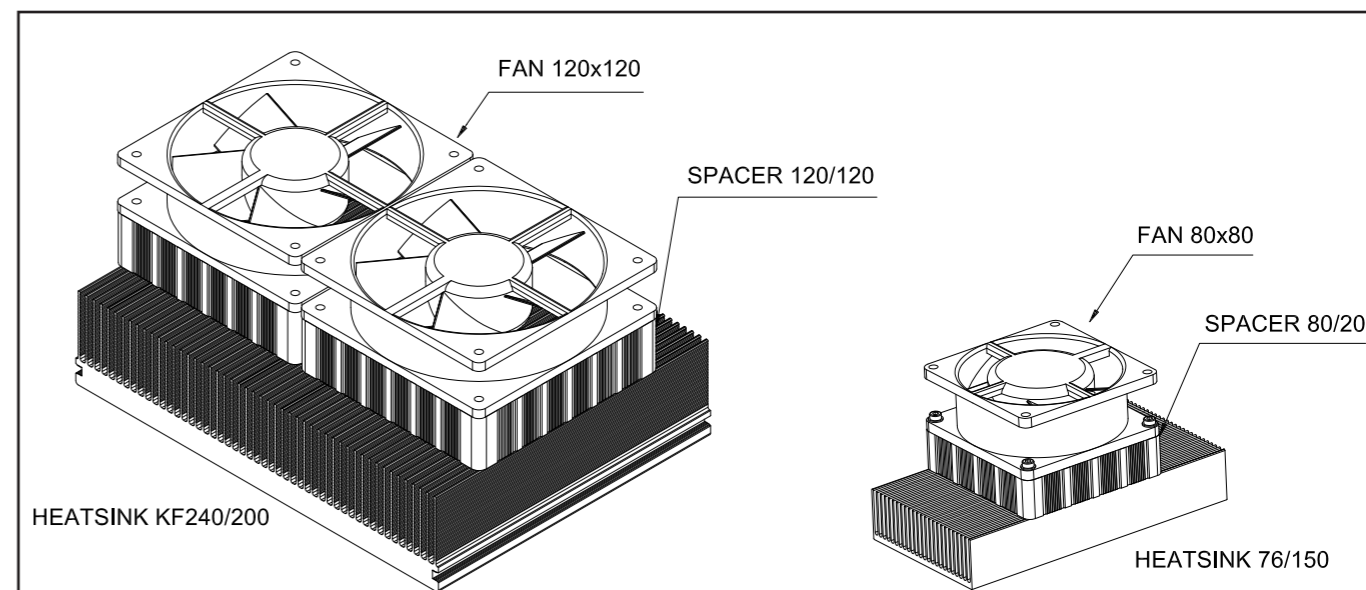

Articolo Item	KF240/200	Ventilazione forzata Forced ventilation	2 FANS 120x120x38 D.C. 24V	Rt °C/W	0,042
---------------	-----------	---	----------------------------	---------	-------

Articolo Item	K76/150	Ventilazione forzata Forced ventilation	1 FAN 80x80x20 D.C. 24V	Rt °C/W	0,156
---------------	---------	---	-------------------------	---------	-------

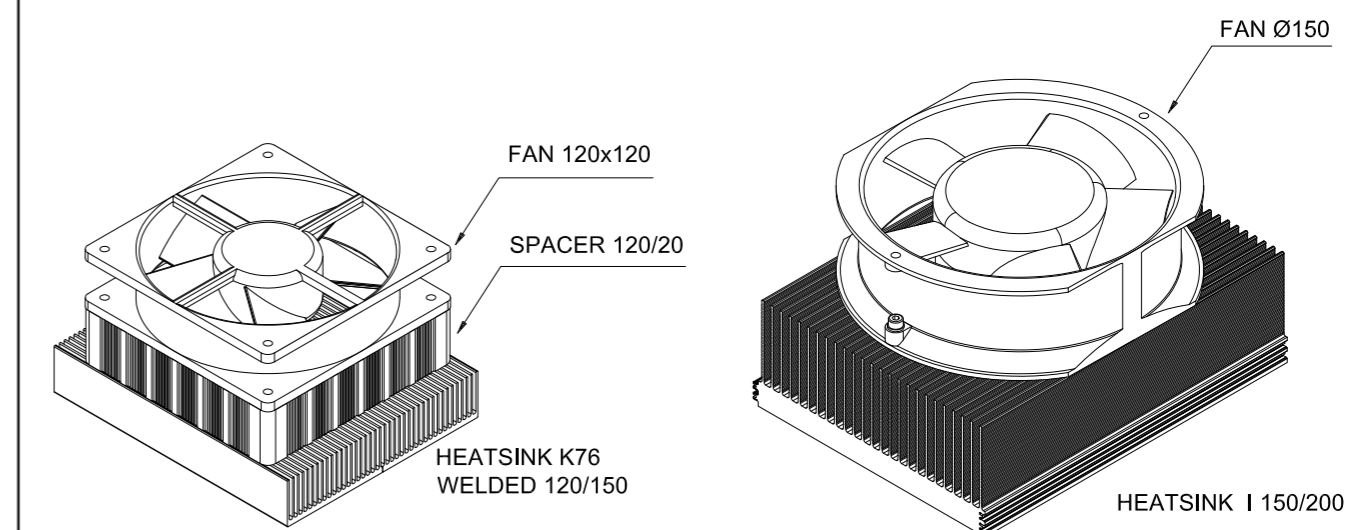

Articolo Item	2xK76/120 CUT 120	Ventilazione forzata Forced ventilation	1 FAN 120x120x38 D.C. 24V	Rt °C/W	0,11
---------------	-------------------	---	---------------------------	---------	------

Articolo Item	I 150/200	Ventilazione forzata Forced ventilation	1 FAN Ø 150 D.C. 24V	Rt °C/W	0,059
---------------	-----------	---	----------------------	---------	-------

Utilizzando profili speciali con il sistema della ventilazione impinge si possono ottenere delle cool plates veramente molto interessanti dal momento che uniscono una grandissima efficienza ad un costo ottimizzato. Le dimensioni testate in laboratorio e riportate nel presente catalogo sono comunque da considerarsi solo come ottimi esempi di impiego. Poiché i profili sono integrali e non hanno le limitazioni dei modulari, questi articoli possono essere ottimamente impiegati anche per carichi molto concentrati.

Using special profiles with impinge ventilation can obtain very good cool plates with a ratio cost/efficiency very interesting. In the catalog can be found some tested examples, but customer can request any other dimension. Those profiles are integral profiles and are better than modular profiles.

# PROFILI INTEGRALI AD ALTA EFFICIENZA IN VENTILAZIONE FORZATA

## HIGH EFFICIENCY INTEGRAL PROFILES IN FORCED VENTILATION

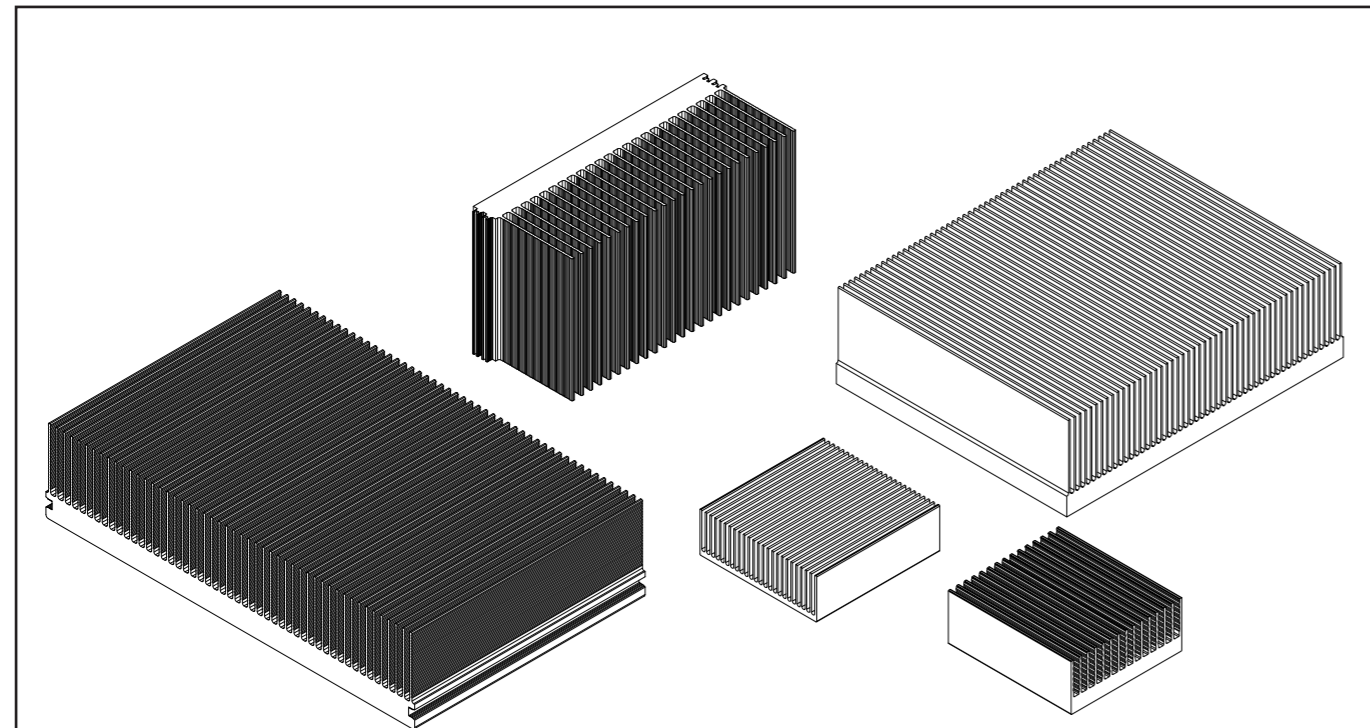

La nascita dei profili modulari ad alta efficienza in ventilazione forzata, ha aperto la strada al progettista elettronico all'impiego nelle migliori condizioni possibili della nuova componentistica basata su moduli ad altissima concentrazione di iniezione di calore sul dissipatore. Purtroppo il profilo modulare non è esente da tutta una serie di problemi dal punto di vista meccanico perché se viene assemblato con colla non può essere evitato un sensibile aumento della resistenza termica trasversale fra modulo e modulo, mentre se viene utilizzato un sistema puramente meccanico a deformazione, quando si raggiungono certe dimensioni il rischio di collasso del pezzo assemblato è molto alto.

Per questi motivi la Tecnoal ha progettato e implementato una tecnologia particolare per garantire che i prodotti finali siano perfettamente sicuri e ripetibili sia dal punto di vista meccanico che termico. Dal momento che con l'estrusione integrale non si può andare oltre certi limiti sia dimensionali che di rapporti, viene utilizzata una soluzione ibrida che permette di impiegare il sistema ad incastro rinforzato ove sia necessario con la saldatura.

Con questo sistema che l'azienda gestisce integralmente all'interno della propria struttura si possono ottenere profili di grandi dimensioni, ma con rapporti alettali veramente efficienti, tali da consentire una continuità di prestazioni e qualità non ottenibili per altre vie.

Tutti i profili di questa serie sono gestiti a magazzino in barre di lunghezza compresa tra i 3 e i 5 m a seconda dei modelli e del relativo peso al metro lineare.

Tecnoal è in grado di fornire il particolare comprensivo di tutte le lavorazioni e di eventuali trattamenti superficiali.

Qualora volesse richiederci una qualsiasi quotazione vi preghiamo di fornirci le seguenti informazioni:

- 1 - Profilo e relativa lunghezza di taglio (Esempio: KF240/350 - viene così indicato il profilo KF240 tagliato a 350mm).
- 2 - Quantitativo del lotto di produzione.
- 3 - Eventuali lavorazioni meccaniche da eseguire, meglio se corredate da un file contenente un disegno tecnico nei formati pdf, dwg, dxf. Questi ultimi due possono essere importati direttamente nel nostro sistema CAD-CAM consentendo una tempistica più breve. Vi invitiamo a fornire sempre disegni dove le quote non siano state forzate.
- 4 - Specificare eventuali trattamenti superficiali, quali anodizzazione (indicare il colore), alodine, ecc....

Il nostro ufficio commerciale e tecnico è a Vostra completa disposizione per qualsiasi chiarimento.

The birth of high efficiency modular profiles in forced ventilation opened the way to electronic designer the employ in the best possible condition new components based on modules with very high concentration of heat injection on the heatsink.

Unfortunately modular profile can be affected by mechanical problems, because if assembled with glue there is a significant increase in cross thermal resistance between module and module while if assembled with purely mechanical deformation, when we reach certain size the risk of collapse of assembled piece is very high. For these reasons Tecnoal has designed and implemented a technology to ensure that final product are perfectly safe and with reliable mechanical and thermal characteristics.

While with integral extrusion cannot be exceeded the ratio between step and height of fins, a hybrid solution using press system reinforced where necessary by welding, is the right technical approach.

With this system fully available in Tecnoal large profiles can be obtained but with fins ratio truly efficient, which would allow a continuity of performance and quality that cannot be obtained by other means.

All profiles in this series are stored in bars 3 to 5 meters long depending on the models and relative weight per mt.

Tecnoal is able to provide these items including all machining and any surface treatments.

For quotations please provide the following informations:

- 1 - Profile and relevant length (Example: KF240/350 - specifies the profile KF240 cut to 350mm).
- 2 - Quantity of batch production.
- 3 - Any machining, preferably accompanied by a file containing a technical drawing in pdf, dwg, dxf format. Dwg and dxf formats can be imported directly into our system CAD-CAM allowing a shorter time. Please provide drawing always where dimensions have not been forced.
- 4 - Specify any surface treatments such anodization including color, alodine etc...

Our commercial and technical office is at your disposal for any clarification.

**KA66**

Peso Kg/m  
Weight Kg/m **5.10**

Rt °C/W **1.59**

Lung. campione mm  
Sample length mm **100**

Ventilazione forzata  
Forced ventilation

Rt °C/W **0.22**

Velocità dell'aria in uscita (m/sec)  
Outgoing air speed (m/sec) **3.0**

Lung. campione mm  
Sample length mm **100**

TECNOAL BOLOGNA - ITALY

**K72**

Peso Kg/m  
Weight Kg/m **3.10**

Rt °C/W **2.30**

Lung. campione mm  
Sample length mm **100**

Ventilazione forzata  
Forced ventilation

Rt °C/W **0.32**

Velocità dell'aria in uscita (m/sec)  
Outgoing air speed (m/sec) **3.0**

Lung. campione mm  
Sample length mm **100**

TECNOAL BOLOGNA - ITALY

**K76**

Peso Kg/m  
Weight Kg/m **2.30**

Rt °C/W **1.75**

Lung. campione mm  
Sample length mm **150**

Ventilazione forzata  
Forced ventilation

Rt °C/W **0.21**

Velocità dell'aria in uscita (m/sec)  
Outgoing air speed (m/sec) **3.0**

Lung. campione mm  
Sample length mm **150**

TECNOAL BOLOGNA - ITALY

**K91**

Peso Kg/m  
Weight Kg/m **1.07**

Rt °C/W **3.35**

Lung. campione mm  
Sample length mm **100**

Ventilazione forzata  
Forced ventilation

Rt °C/W **0.325**

Velocità dell'aria in uscita (m/sec)  
Outgoing air speed (m/sec) **3.0**

Lung. campione mm  
Sample length mm **100**

TECNOAL BOLOGNA - ITALY

<b>KF126</b>	Peso Kg/m Weight Kg/m	<b>4.38</b>	Rt °C/W	<b>0.5</b>	Lung. campione mm Sample length mm	<b>100</b>
--------------	--------------------------	-------------	---------	------------	---------------------------------------	------------

Ventilazione forzata Forced ventilation	Rt °C/W	<b>0.147</b>	Velocità dell'aria in uscita (m/sec) Outgoing air speed (m/sec)	<b>5.0</b>	Lung. campione mm Sample length mm	<b>100</b>
--	---------	--------------	--	------------	---------------------------------------	------------

TECNOAL BOLOGNA - ITALY

<b>K133</b>	Peso Kg/m Weight Kg/m	<b>7.53</b>	Rt °C/W	<b>0.78</b>	Lung. campione mm Sample length mm	<b>100</b>
-------------	--------------------------	-------------	---------	-------------	---------------------------------------	------------

Ventilazione forzata Forced ventilation	Rt °C/W	<b>0.074</b>	Velocità dell'aria in uscita (m/sec) Outgoing air speed (m/sec)	<b>3.0</b>	Lung. campione mm Sample length mm	<b>150</b>
Ventilazione forzata Forced ventilation	Rt °C/W	<b>0.062</b>	Velocità dell'aria in uscita (m/sec) Outgoing air speed (m/sec)	<b>5.0</b>	Lung. campione mm Sample length mm	<b>150</b>

TECNOAL BOLOGNA - ITALY

<b>K138</b>	Peso Kg/m Weight Kg/m	<b>9.60</b>	Rt °C/W	<b>0.80</b>	Lung. campione mm Sample length mm	<b>200</b>
-------------	--------------------------	-------------	---------	-------------	---------------------------------------	------------

Ventilazione forzata Forced ventilation	Rt °C/W	<b>0.079</b>	Velocità dell'aria in uscita (m/sec) Outgoing air speed (m/sec)	<b>5.0</b>	Lung. campione mm Sample length mm	<b>200</b>
--	---------	--------------	--	------------	---------------------------------------	------------

TECNOAL BOLOGNA - ITALY

<b>I 150</b>	Peso Kg/m Weight Kg/m	<b>10.5</b>	Rt °C/W	<b>0.56</b>	Lung. campione mm Sample length mm	<b>200</b>
--------------	--------------------------	-------------	---------	-------------	---------------------------------------	------------

ONLY FOR FORCED VENTILATION

Ventilazione forzata Forced ventilation	Rt °C/W	<b>0.075</b>	Velocità dell'aria in uscita (m/sec) Outgoing air speed (m/sec)	<b>5.0</b>	Lung. campione mm Sample length mm	<b>200</b>
--	---------	--------------	--	------------	---------------------------------------	------------

TECNOAL BOLOGNA - ITALY

<b>KF163</b>	Peso Kg/m Weight Kg/m	<b>12.90</b>	Rt °C/W	<b>0.56</b>	Lung. campione mm Sample length mm	<b>150</b>
--------------	--------------------------	--------------	---------	-------------	---------------------------------------	------------

Ventilazione forzata Forced ventilation	Rt °C/W	<b>0.074</b>	Velocità dell'aria in uscita (m/sec) Outgoing air speed (m/sec)	<b>3.0</b>	Lung. campione mm Sample length mm	<b>150</b>
Ventilazione forzata Forced ventilation	Rt °C/W	<b>0.062</b>	Velocità dell'aria in uscita (m/sec) Outgoing air speed (m/sec)	<b>5.0</b>	Lung. campione mm Sample length mm	<b>150</b>

TECNOAL BOLOGNA - ITALY

<b>KF212</b>	Peso Kg/m Weight Kg/m	<b>8.20</b>	Rt °C/W	<b>0.85</b>	Lung. campione mm Sample length mm	<b>150</b>
--------------	--------------------------	-------------	---------	-------------	---------------------------------------	------------

Ventilazione forzata Forced ventilation	Rt °C/W	<b>0.074</b>	Velocità dell'aria in uscita (m/sec) Outgoing air speed (m/sec)	<b>3.0</b>	Lung. campione mm Sample length mm	<b>150</b>
Ventilazione forzata Forced ventilation	Rt °C/W	<b>0.062</b>	Velocità dell'aria in uscita (m/sec) Outgoing air speed (m/sec)	<b>5.0</b>	Lung. campione mm Sample length mm	<b>150</b>

TECNOAL BOLOGNA - ITALY

<b>KF215</b>	Peso Kg/m Weight Kg/m	<b>16.75</b>	Rt °C/W	<b>0.637</b>	Lung. campione mm Sample length mm	<b>150</b>
--------------	--------------------------	--------------	---------	--------------	---------------------------------------	------------

Ventilazione forzata Forced ventilation	Rt °C/W	<b>0.043</b>	Velocità dell'aria in uscita (m/sec) Outgoing air speed (m/sec)	<b>5.0</b>	Lung. campione mm Sample length mm	<b>150</b>
--	---------	--------------	--	------------	---------------------------------------	------------

TECNOAL BOLOGNA - ITALY

<b>KF240</b>	Peso Kg/m Weight Kg/m	<b>16.50</b>	Rt °C/W	<b>0.54</b>	Lung. campione mm Sample length mm	<b>150</b>
--------------	--------------------------	--------------	---------	-------------	---------------------------------------	------------

ONLY FOR FORCED VENTILATION

Ventilazione forzata Forced ventilation	Rt °C/W	<b>0.043</b>	Velocità dell'aria in uscita (m/sec) Outgoing air speed (m/sec)	<b>6.0</b>	Lung. campione mm Sample length mm	<b>200</b>
--	---------	--------------	--	------------	---------------------------------------	------------

TECNOAL BOLOGNA - ITALY

# PROFILI MODULARI SERIE "I"

## SERIES "I" MODULAR PROFILES

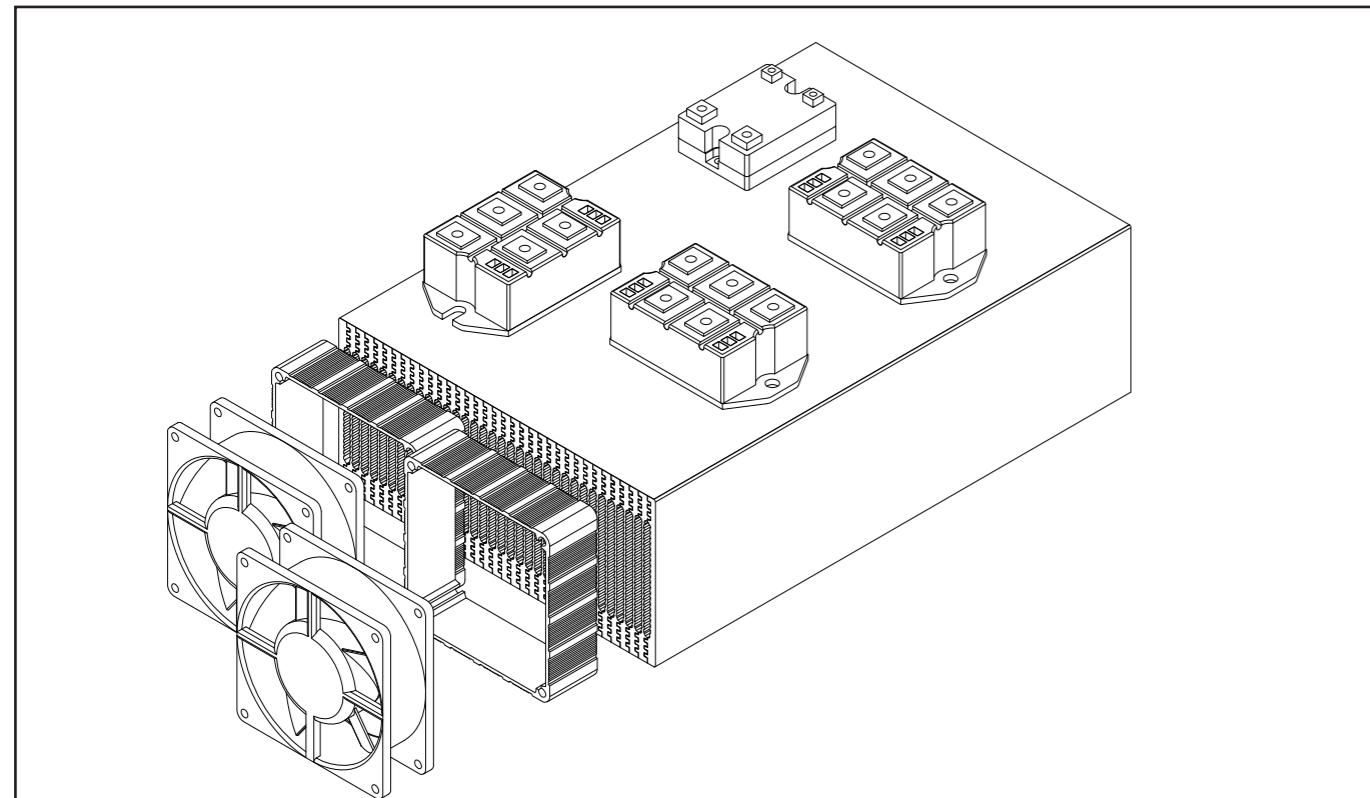

I profili della serie "I" formano la linea dei dissipatori a moduli incastrati denominata "TecnoPower".

I dissipatori appartenenti a questa serie offrono una grandissima efficienza in ventilazione forzata in quanto la superficie alettata a contatto con l'aria è estremamente elevata.

Le dimensioni sono molto flessibili essendo fissa solo l'altezza dell'elemento.

Tecnoal è in grado di fornire i pezzi comprensivi di tutte le lavorazioni meccaniche.

Possono essere realizzati nuovi profili su specifiche esigenze del cliente.

Qualora voleste richiederci una qualsiasi quotazione vi preghiamo di fornirci le seguenti informazioni:

- 1- Profilo assemblato alla larghezza richiesta e relativa lunghezza di taglio (Esempio: I75Ax300/400 - viene così indicato il profilo I75A assemblato alla larghezza di 300mm e tagliato alla lunghezza di 400mm).
- 2- Quantitativo del lotto di produzione
- 3- Eventuali lavorazioni meccaniche da eseguire, meglio se corredate da un file contenente un disegno tecnico nei formati pdf, dwg, dxf. Questi ultimi due possono essere importati direttamente nel nostro sistema CAD-CAM consentendo una tempistica più breve. Vi invitiamo a fornire sempre disegni dove le quote non siano state forzate.

**Qualora non vengano espressamente richieste le chiusure laterali, sarà a nostra discrezionalità stabilirne l'eventuale impiego al fine di ottimizzare le dimensioni del pezzo finito.**

Il nostro ufficio commerciale e tecnico è a Vostra completa disposizione per qualsiasi chiarimento.

Series "I" profiles form the line of press fit heatsink pressed modules called "TecnoPower."

The heatsinks belonging to this series offer a great efficiency in forced ventilation because the fins surface in contact with the air is extremely high.

The dimensions are very flexible being fixed only the height of the module.

Tecnoal is able to provide the pieces with full machining and new profiles can be made on specific customer requirement.

For quotations please provide the following informations:

- 1 - Profile assembled at width and length requested (Example: I75Ax300/400 specifies the profile I 75A assembled at width 300mm and cut to 400mm).
- 2 - Quantity of batch production.
- 3 - Any machining, preferably accompanied by a file containing a technical drawing in pdf, dwg, dxf format. Dwg and dxf formats can be imported directly into our system CAD-CAM allowing a shorter time. Please provide drawing always where dimensions have not been forced.

**When side closures are not expressly required, will be at our discretion to determine their possible use in order to optimize the size of the finished piece.**

Our commercial and technical office is at your disposal for any clarification.

La nascita dei profili modulari ad alta efficienza in ventilazione forzata ha aperto la strada al progettista elettronico all'impiego nelle migliori condizioni possibili della nuova componentistica basata su moduli ad altissima concentrazione di iniezione di calore sul dissipatore. Inoltre una nuova famiglia di ventole ad altissima efficienza è stata lanciata sul mercato negli ultimi tempi provocando una grande rivoluzione sui parametri dei nuovi progetti sempre rivolti ad ottenere il massimo risultato con il minimo dei costi.

Tecnoal in virtù della vasta esperienza nel settore della ventilazione forzata, ha ampliato la gamma delle più importanti famiglie dei profili modulari specialmente quella del I84 e del I125 per ottenere il miglior risultato per tutti i nuovi progetti.

### APPLICAZIONI

Tutti i profili della serie TECNOPOWER sono progettati per ottenere le migliori prestazioni in ventilazione forzata. Si può operare in due modi ovvero:

- Ventilazione longitudinale
- Ventilazione radiale o impinge.

Maggiore efficienza si ottiene in compressione, per operare in aspirazione scegliere possibilmente alette lisce.

### NOTE TECNICHE (INDICAZIONI GENERALI)

Tutti modelli della serie TECNOPOWER sono in lega di alluminio EN AW-6060 o 6063.

Le superfici sulle quali vengono montati i componenti elettronici sono spianate con una planarità di 0,02 mm/150 mm. e la rugosità massima è di Ra = 1,2 micron.

La finitura standard è il lavaggio (sgrassaggio).

### DISSIPATORI MODULARI DI GRANDI DIMENSIONI

Con il sistema di assemblaggio Tecnoal si possono ricavare particolari di notevoli dimensioni, sia in larghezza che in lunghezza. La dimensione più critica è senz'altro la larghezza soprattutto perché al di sopra di una certa dimensione il peso relativo contribuisce a complicare enormemente tutte le lavorazioni, le movimentazioni e, di conseguenza, la qualità totale.

Per garantire la costanza e la sicurezza delle caratteristiche meccaniche su particolari con pesi superiori ai 50 Kg. e dimensioni superiori ai 500 mm., Tecnoal ha integrato nelle normali procedure di costruzione l'aggiunta di un cordolo di saldatura da applicare nelle posizioni più opportune. I parametri possono cambiare a seconda della geometria del profilo e delle particolari caratteristiche di rigidità e resistenza.

Per quello che riguarda tutte le tolleranze sulle dimensioni finali è stata elaborata sulla dimensione larghezza la seguente tabella valida in base ai campi di misura.

TABLE FOR TOLLERANCES FOR MODULAR PROFILE			
WHIDTH MEASURES	TOLLERANCE IN mm.	ALTERNATIVE TOLLERANCE IN mm.	ALTERNATIVE TOLLERANCE IN mm.
UNTILL TO 100 mm.	± 0.5	+ 1 0	0 - 1
FROM 100mm. TO 150mm.	± 0.7	+ 1.5 0	0 - 1.5
FROM 150mm. TO 250mm.	± 1	+ 2 0	0 - 2
FROM 250mm. TO 400mm.	± 1.5	+ 3 0	0 - 3
FROM 400mm. TO 700mm.	± 2	+ 4 0	0 - 4
FROM 700mm. TO 1000mm.	± 2.5	+ 5 0	0 - 5

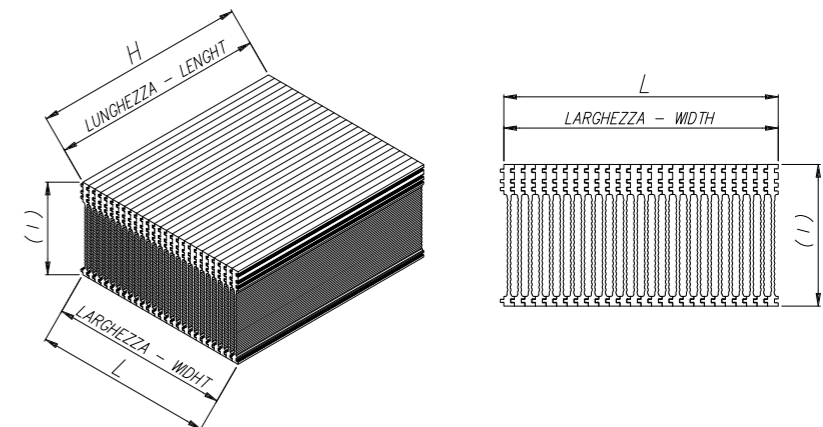

Tolleranze di lunghezza ± 0,5 mm. da 0 a 400 mm.

Tolleranze di lunghezza ± 1 mm. da 400 a 1000 mm.

Tolleranze di lunghezza oltre i 1000 mm. +/- 2 mm.

Tolleranze di ortogonalità ± 1°

Tolleranze di planarità ± 0,03 mm./100 mm. nelle zone di appoggio dei componenti.

Tolleranze di rugosità Ra= 1,6 medio nelle zone di appoggio dei componenti. Sono escluse le zone di giunzione dei moduli dove è ammessa una distanza massima di 0,15 mm.

Poiché al termine di tutte le lavorazioni i particolari subiscono al momento dell'imballo un controllo finale, tutte le difettosità visive che possono evidenziarsi che non vanno però ad interferire sul buon funzionamento del pezzo, devono essere accettate perché è particolarmente difficile preservare pezzi di grande peso e dimensione da piccole imperfezioni causate dalle lavorazioni e dalle successive movimentazioni. Ricordiamo inoltre come già riportato all'inizio del catalogo che le caratteristiche generali fanno riferimento alle norme UNI EN 755/9 riguardanti i profili estrusi.

Precisiamo altresì che salvo indicazione contraria i pezzi non conformi alle tolleranze generali non possono essere automaticamente rifiutati quando la loro funzionalità non risulta compromessa.

**Tecnoal si riserva il diritto di apportare modifiche e migliorie ai prodotti senza obbligo di preavviso con l'unica condizione che questa operazione non comprometta la funzionalità del pezzo.**

The birth of high efficiency modular profiles in forced ventilation opened the way to electronic designer for employ in the best possible condition new components based on modules with very high concentration of heat injection on the heatsink.

More-over a new family of high efficiency fans born on last time has changed all parameters on electronic projects and for reach maximum result with minimum cost is very hard. Tecnoal using his big experience on forced ventilation field has increased all type of the most important family of modular profiles and especially I84 and I125 family for have the best result in all type of new projects.

### APPLICATIONS

All modular profiles TECNOPOWER are optimized for forced ventilation. We can work in two systems:

- Longitudinal ventilation
- Radial or impinge ventilation.

More efficiency can be obtained in pumping use, in sucking use is better smoothed fins.

### TECHNICAL NOTE (GENERAL INDICATION)

All modular profiles TECNOPOWER are in aluminum alloy EN AW-6060 or 6063.

The components assembly surfaces are milled as following data: Planarity 0,02mm/150 mm.

Maximum Roughness = Ra 1,2 Microns.

### LARGE TECNOPOWER ASSEMBLED HEATSINKS

Through Tecnoal assembly process heatsinks of large dimensions can be obtained.

Surely the most critical dimension is width. However when the length is very high the relative weight contribute to make all process and handling much more consequent unpleasant impact on the total quality. For guarantee the constancy of quality and mechanical characteristic on pieces with weight superior to 50 Kg. and dimension over 500 mm., Tecnoal has added a welding strip where most needed to the regular manufacturing procedures. The parameters can be change based on profile geometry, on rigidity and strength characteristics. About dimension tolerances for width standard measures are in the following table.

Length tolerance +/- 0,5 mm. from 0 to 400 mm.

Length tolerance +/- 1 mm. from 400 to 1.000 mm.

Length tolerance up to 1.000 mm. +/- 2 mm.

Orthogonality tolerance +/- 1°

Planarity tolerance +/- 0,03 mm./100 mm. on components apply zone

Roughness tolerance Ra= 1,6 microns medium on components apply zone. Maximum distance of 0,15 mm. is admitted on ribs joint zone.

Since all these characteristics are subject to final control, all visible defects not impacting on product functionality need to be accepted because is very difficult to preserve large size products from light imperfection caused by manufacturing and handling.

As already underlined in the beginning of our catalogue, we remind besides general characteristics are referred to UNI EN 755/9 rules for extruded profiles.

**Unless otherwise stated the products that do not comply with general tolerances cannot be automatically rejected when their functionality is not compromised.**

# SISTEMA DI VENTILAZIONE

# VENTILATION SYSTEM

## VENTILAZIONE ASSIALE O LONGITUDINALE

Nella ventilazione longitudinale il flusso dell'aria generato dalle ventole attraversa tutta la lunghezza del dissipatore.

Si avrà perciò il massimo delle perdite di carico del flusso dell'aria insieme con la formazione di forti gradienti termici.

Evidenziamo altresì che, qualora le dimensioni del progetto lo consentano, è importante inserire fra la ventola e il dissipatore uno spacer per ottimizzare il flusso dell'aria.

Facciamo notare infine che con questo tipo di ventilazione è possibile caricare entrambe le facce del dissipatore se non è a pettine.

## LONGITUDINAL VENTILATION

In longitudinal ventilation the air flow generated by the cooling fans flows through the whole length of the heat sink.

This implies the maximum pressure drop in airflow with high thermal gradients.

In this case if allowed by the size of the project, it is very important to install between the fan and the heat sink a spacer to optimize the airflow.

With this type of ventilation it is possible to put the thermal load on both sides of the heat sink if the heat sink is not comb shaped.

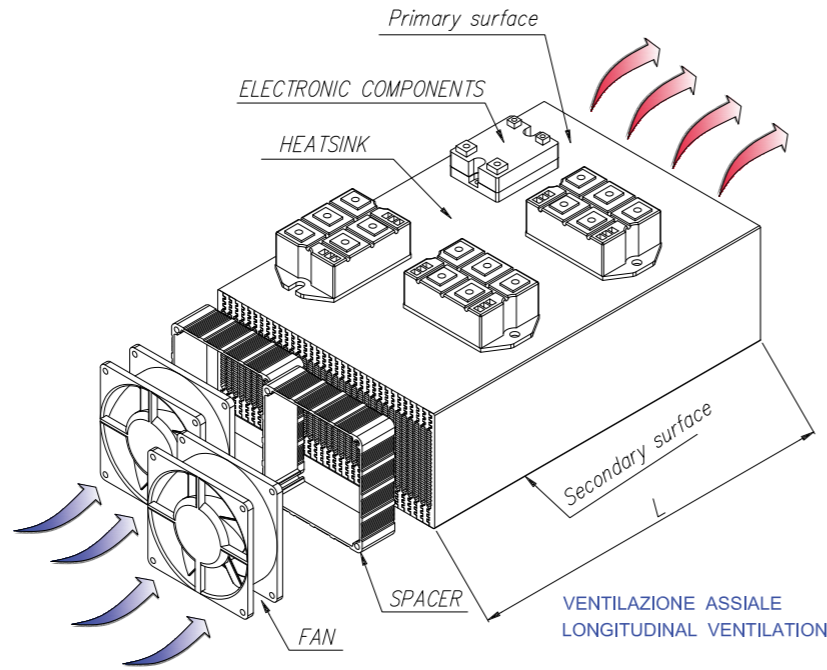

## VENTILAZIONE RADIALE

Nella ventilazione impinge o radiale abbiamo contemporaneamente due notevoli vantaggi: il dimezzamento del percorso dell'aria con conseguenti minor perdite di carico e la forte diminuzione dei gradienti termici, il che consente di portare il rendimento del dissipatore al massimo.

Si può operare sia in aspirazione che in compressione, ma è assolutamente preferibile lavorare in compressione; ciò consente l'ottimizzazione dei percorsi dell'aria.

Operando tagli trasversali delle alette si può ottenere l'uscita dell'aria su tutti e quattro i lati del dissipatore, ma non si ottengono particolari vantaggi di efficienza.

Anche in questa configurazione se il dissipatore è chiuso è consigliabile montare la ventola interponendo uno spacer.

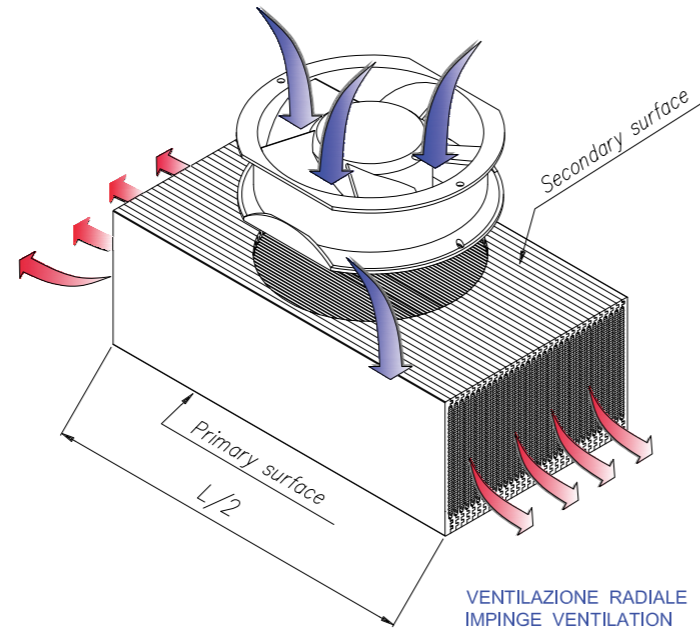

## IMPINGE VENTILATION

Impinge or radial ventilation grants two important features: half flow path length, with consequent lower "pressure drop", and high thermal gradients reduction, with maximization of heat sink efficiency.

Both suction or compression operation modes are possible but compression mode is preferred because enables the optimization of air run.

It is also possible to get the exit of the air flow from the four sides of the heat sink by means of cross-cut fins, but without obtaining improvements in efficiency.

Also in this configuration, if the heat sink is closed, it is convenient to install the cooling fan inserting a spacer.

## CONDIZIONI DI PROVA - TEST'S STATE

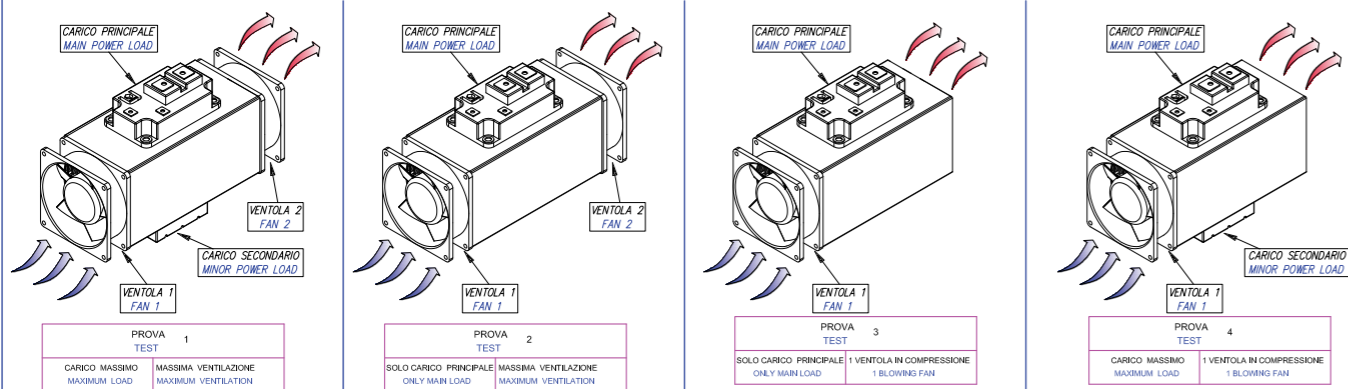

## I 40A

Peso Kg/m 0.30  
Weight Kg/m 0.30

Dimension H on request  
Dimension L on request

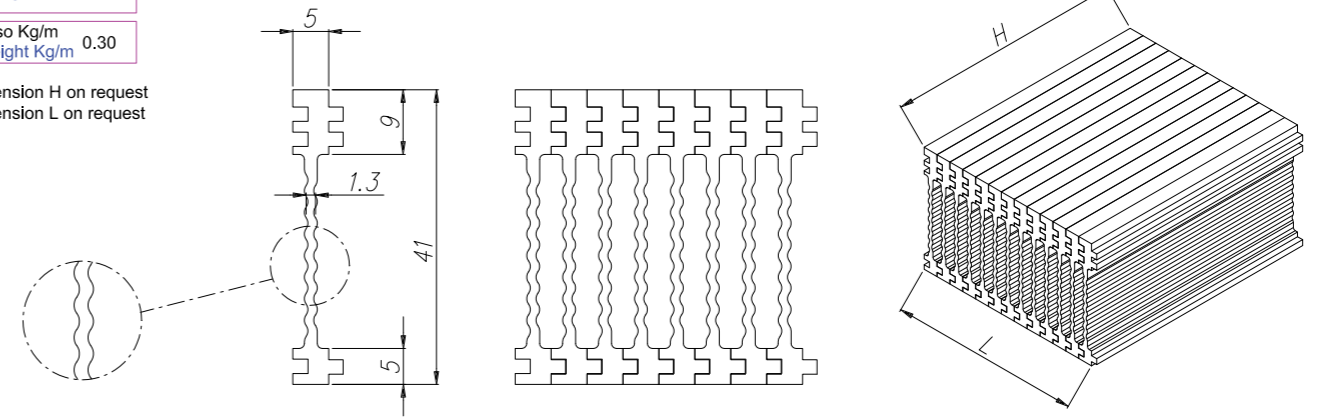

A

PROVA TEST	CARICO PRINCIPALE MAIN POWER LOAD W	CARICO SECONDARIO MINOR POWER LOAD W	VENTOLA 1 FAN 1 TYPE 40x40x20 DC	VENTOLA 2 FAN 2 TYPE 40x40x20 DC	ΔT °C	RT °C/W	VELOCITA' USCITA ARIA OUTGOING AIR SPEED m/sec	D.D.P. mm H <sub>2</sub> O	TEST	
									TEST 1	TEST 2
1	200	50	*	*	70.5	0.2820	2.5			
2	242		*	*	73.0	0.3016	2.5			
3	200		*		63.5	0.3175	1.5	1.8		
4	200	50	*		74.0	0.2960	1.5	1.8		

TECNOAL BOLOGNA - ITALY

## I 40M

Peso Kg/m 0.25  
Weight Kg/m 0.25

Dimension H on request  
Dimension L on request

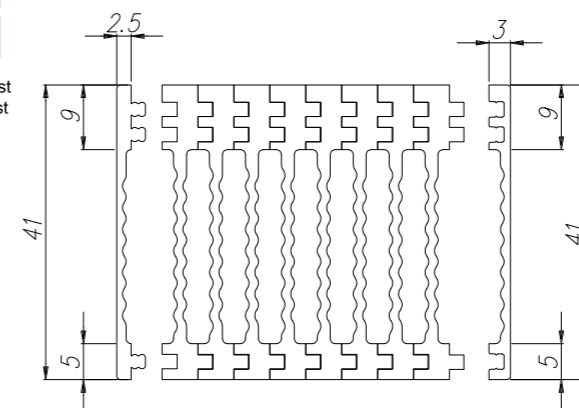

## I 40F

Peso Kg/m 0.21  
Weight Kg/m 0.21

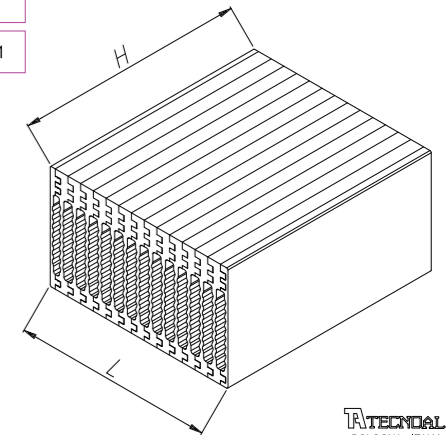

B

TECNOAL BOLOGNA - ITALY

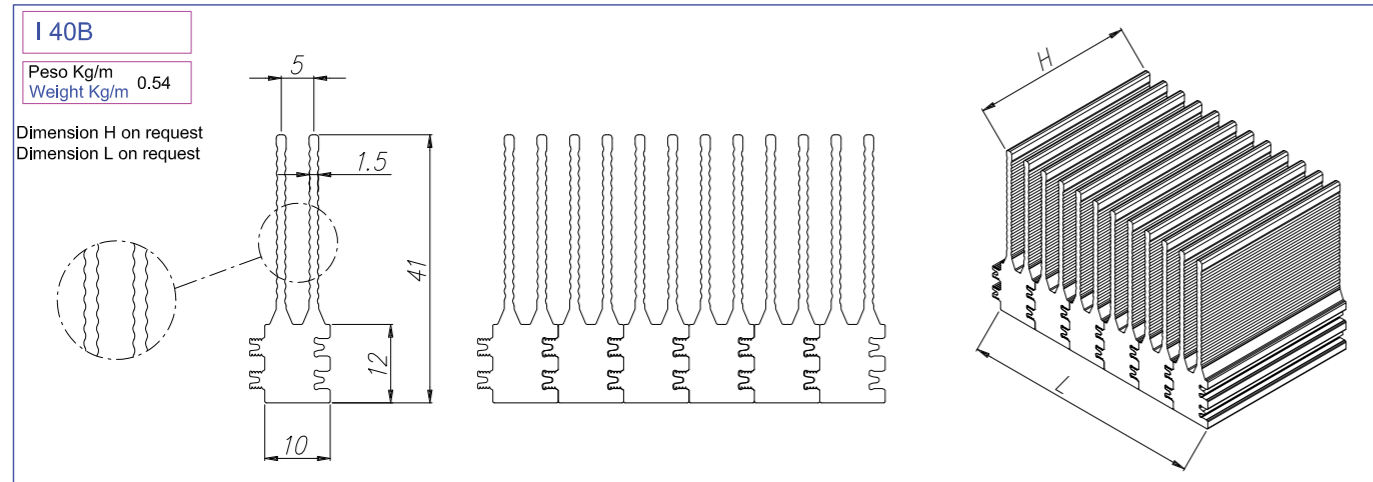

DATA SHEET		PART NUMBER		I 40Bx80/150		I	L	H		
						40	80	150		
PROVA TEST	CARICO PRINCIPALE MAIN POWER LOAD W	CARICO SECONDARIO MINOR POWER LOAD W	VENTOLA 1 FAN 1 TYPE 40x40x20 DC	VENTOLA 2 FAN 2 TYPE 40x40x20 DC	ΔT °C	RT °C/W	VELOCITA' USCITA ARIA OUTGOING AIR SPEED m/sec	D.D.P. mm H <sub>2</sub> O		
2	250		*	*	57	0.228	2.5			
3	250		*		48	0.192	3.8	1.7		

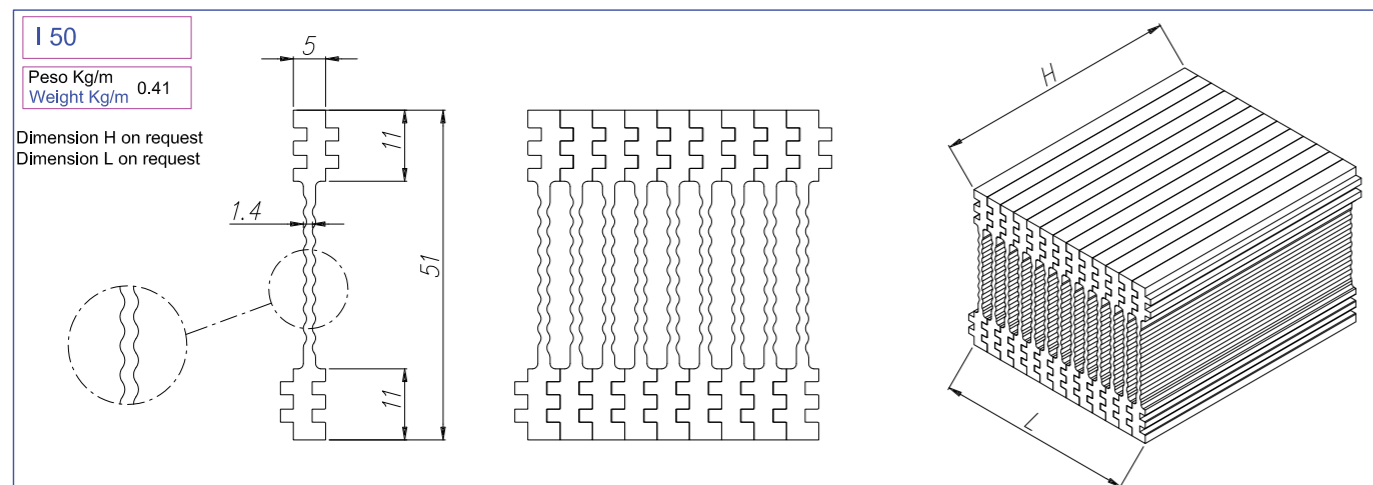

DATA SHEET		PART NUMBER		I 50x80/150		I	L	H		
						50	80	150		
PROVA TEST	CARICO PRINCIPALE MAIN POWER LOAD W	CARICO SECONDARIO MINOR POWER LOAD W	VENTOLA 1 FAN 1 TYPE 40x40x20 DC	VENTOLA 2 FAN 2 TYPE 40x40x20 DC	ΔT °C	RT °C/W	VELOCITA' USCITA ARIA OUTGOING AIR SPEED m/sec	D.D.P. mm H <sub>2</sub> O		
1	200	200	*	*	59	0.147	3.5			
2	250		*	*	53	0.212	3.5			
3	250		*		56	0.224	2.5	2.8		
4	200	200	*		62	0.155	2.5	2.8		

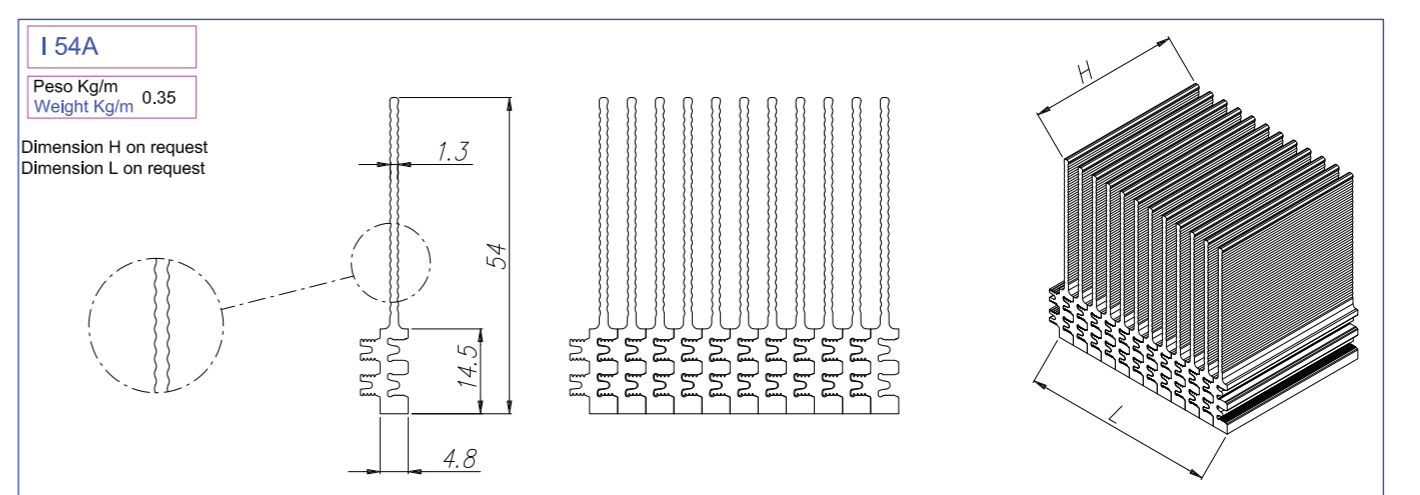
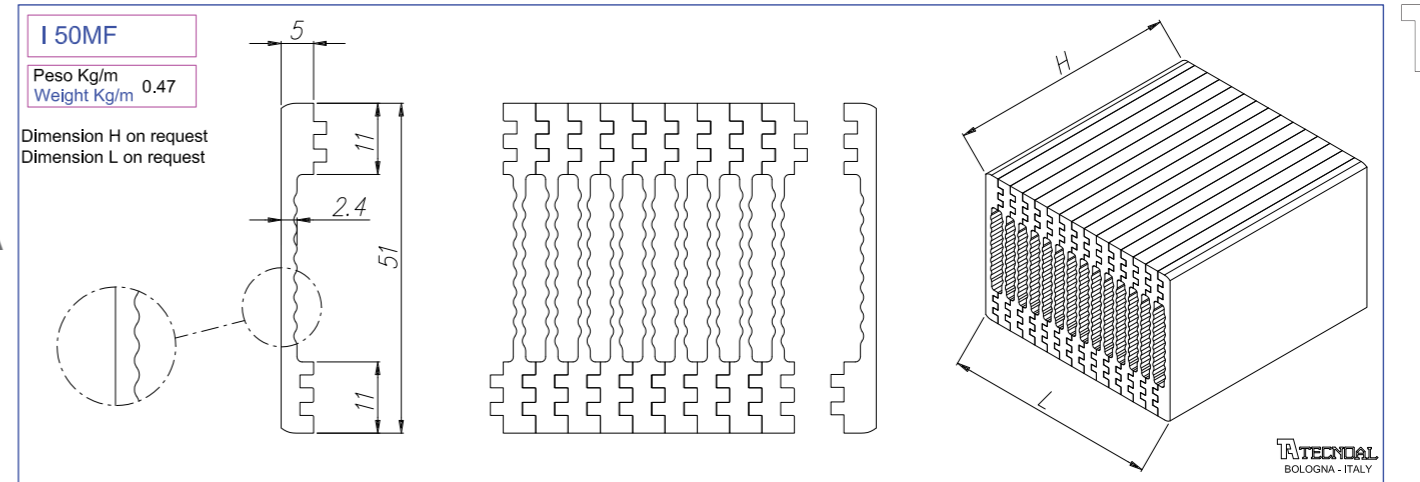

DATA SHEET		PART NUMBER		I 54Ax80/150		I	L	H		
						54	80	150		
PROVA TEST	CARICO PRINCIPALE MAIN POWER LOAD W	CARICO SECONDARIO MINOR POWER LOAD W	VENTOLA 1 FAN 1 TYPE 40x40x28 DC	VENTOLA 2 FAN 2 TYPE 40x40x28 DC	ΔT °C	RT °C/W	VELOCITA' USCITA ARIA OUTGOING AIR SPEED m/sec	D.D.P. mm H <sub>2</sub> O		
2	360		*	*	45.4	0.1261	6.0			
3	360		*		49.7	0.1381	3.5	2.0		

**I 54D**  
 Peso Kg/m 0.55  
 Weight Kg/m

Dimension H on request  
 Dimension L on request

DATA SHEET	PART NUMBER	I 54Dx80/150			I	L	H						
					54	80	150						
PROVA TEST	CARICO PRINCIPALE MAIN POWER LOAD W	CARICO SECONDARIO MINOR POWER LOAD W	VENTOLA 1 FAN 1 TYPE 40x40x28 DC	VENTOLA 2 FAN 2 TYPE 40x40x28 DC	$\Delta T$ °C	RT °C/W	VELOCITA' USCITA ARIA OUTGOING AIR SPEED m/sec	D.D.P. mm H <sub>2</sub> O	TEST 1	TEST 2	TEST 3	TEST 4	
2	250		*	*	27	0.108	4.5						
3	250		*		32	0.128	3.0	1.8					

TECNOAL BOLOGNA - ITALY

**I 56**  
 Peso Kg/m 0.36  
 Weight Kg/m

Dimension H on request  
 Dimension L on request

DATA SHEET	PART NUMBER	I 56x80/150			I	L	H						
					56	80	150						
PROVA TEST	CARICO PRINCIPALE MAIN POWER LOAD W	CARICO SECONDARIO MINOR POWER LOAD W	VENTOLA 1 FAN 1 TYPE 40x40x28 DC	VENTOLA 2 FAN 2 TYPE 40x40x28 DC	$\Delta T$ °C	RT °C/W	VELOCITA' USCITA ARIA OUTGOING AIR SPEED m/sec	D.D.P. mm H <sub>2</sub> O	TEST 1	TEST 2	TEST 3	TEST 4	
1	250	112	*	*	41	0.1133	6.5						
2	250		*	*	32	0.1280	6.5						
3	250		*		35	0.1400	4.0	1.8					
4	250	112	*		46	0.1271	4.0	1.8					

TECNOAL BOLOGNA - ITALY

**I 55**  
 Peso Kg/m 0.34  
 Weight Kg/m

Dimension H on request  
 Dimension L on request

DATA SHEET	PART NUMBER	I 55x80/150			I	L	H						
					55	80	150						
PROVA TEST	CARICO PRINCIPALE MAIN POWER LOAD W	CARICO SECONDARIO MINOR POWER LOAD W	VENTOLA 1 FAN 1 TYPE 40x40x28 DC	VENTOLA 2 FAN 2 TYPE 40x40x28 DC	$\Delta T$ °C	RT °C/W	VELOCITA' USCITA ARIA OUTGOING AIR SPEED m/sec	D.D.P. mm H <sub>2</sub> O	TEST 1	TEST 2	TEST 3	TEST 4	
1	250	112	*	*	42.5	0.1174	7.0						
2	250		*	*	32.5	0.1300	7.0						
3	250		*		35	0.1400	4.6	1.9					
4	250	112	*		45.4	0.1260	4.6	1.9					

TECNOAL BOLOGNA - ITALY

**I 57**  
 Peso Kg/m 0.40  
 Weight Kg/m

Dimension H on request  
 Dimension L on request

DATA SHEET	PART NUMBER	I 57x80/150			I	L	H						
					57	80	150						
PROVA TEST	CARICO PRINCIPALE MAIN POWER LOAD W	CARICO SECONDARIO MINOR POWER LOAD W	VENTOLA 1 FAN 1 TYPE 40x40x28 DC	VENTOLA 2 FAN 2 TYPE 40x40x28 DC	$\Delta T$ °C	RT °C/W	VELOCITA' USCITA ARIA OUTGOING AIR SPEED m/sec	D.D.P. mm H <sub>2</sub> O	TEST 1	TEST 2	TEST 3	TEST 4	
1	250	112	*	*	44	0.1215	6.3						
2	250		*	*	34.5	0.1380	6.3						
3	250		*		36.5	0.1460	5.0	2.0					
4	250	112	*		47	0.1298	5.0	2.0					

TECNOAL BOLOGNA - ITALY

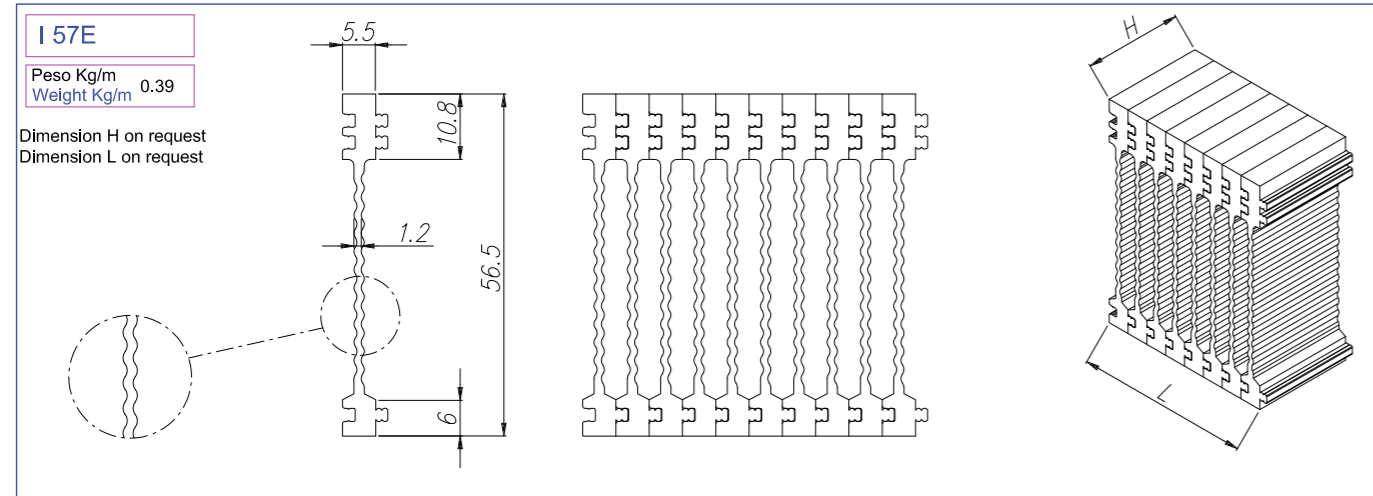

I 57E		Peso Kg/m Weight Kg/m 0.39		Dimension H on request Dimension L on request				
DATA SHEET		PART NUMBER		I 57Ex80/150				
				I	L	H		
				57	80	150		
PROVA TEST	CARICO PRINCIPALE MAIN POWER LOAD W	CARICO SECONDARIO MINOR POWER LOAD W	VENTOLA 1 FAN 1 TYPE 40x40x28 DC	VENTOLA 2 FAN 2 TYPE 40x40x28 DC	$\Delta T$ °C	RT °C/W	VELOCITA' USCITA ARIA OUTGOING AIR SPEED m/sec	D.D.P. mm H <sub>2</sub> O
1	250	112	*	*	44.0	0.1215	6.5	
2	250		*	*	34.5	0.1380	6.5	
3	250		*	*	36.5	0.1460	5.0	2.0
4	250	112	*	*	47.0	0.1293	5.0	2.0

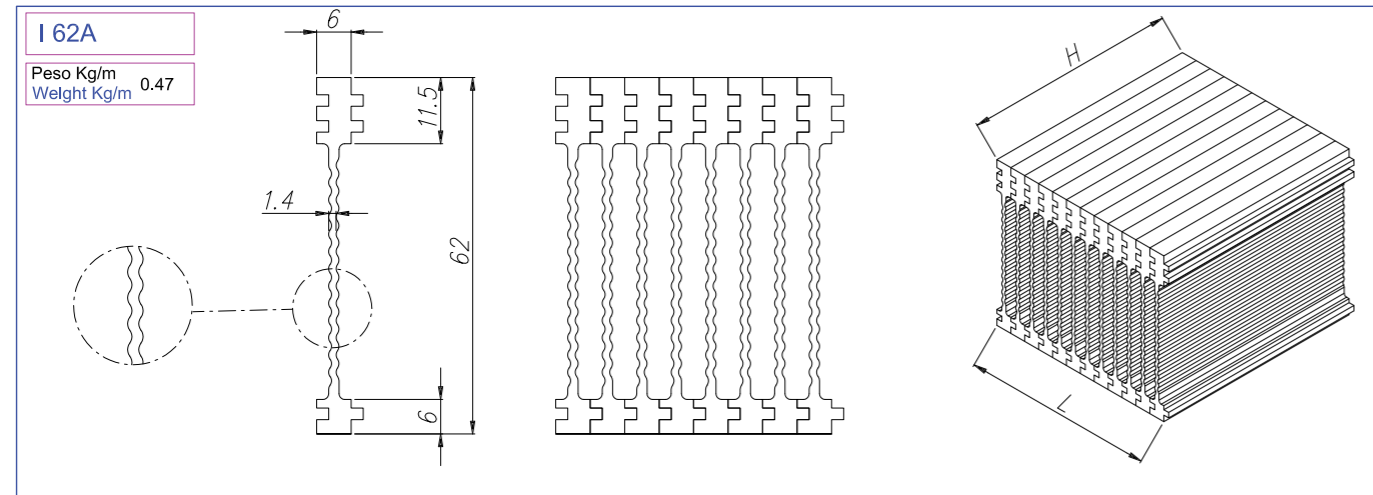

I 62A		Peso Kg/m Weight Kg/m 0.47		Dimension H on request Dimension L on request				
DATA SHEET		PART NUMBER		I 62Ax60/180				
				I	L	H		
				62	60	180		
PROVA TEST	CARICO PRINCIPALE MAIN POWER LOAD W	CARICO SECONDARIO MINOR POWER LOAD W	VENTOLA 1 FAN 1 TYPE 60x60x25 DC	VENTOLA 2 FAN 2 TYPE 60x60x25 DC	$\Delta T$ °C	RT °C/W	VELOCITA' USCITA ARIA OUTGOING AIR SPEED m/sec	D.D.P. mm H <sub>2</sub> O
1	215	72	*	*	60	0.2090	3.0	
2	270		*	*	61	0.2259	3.0	
3	270		*	*	73.5	0.2722	2.5	2.1
4	215	72	*	*	72	0.2508	2.5	2.1

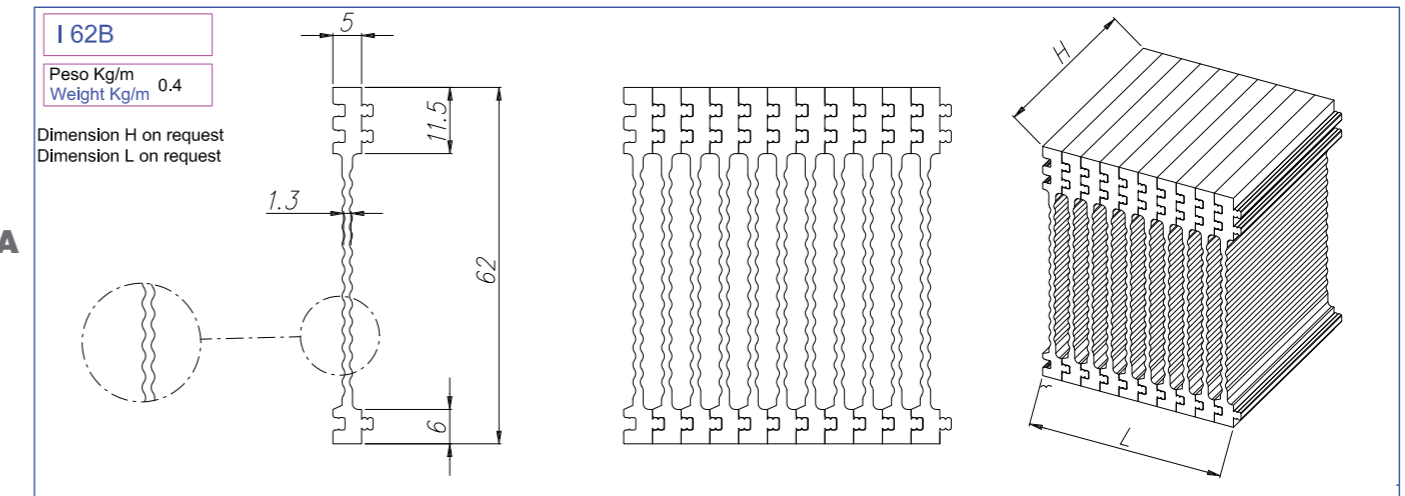

I 62B		Peso Kg/m Weight Kg/m 0.4		Dimension H on request Dimension L on request				
DATA SHEET		PART NUMBER		I 62Bx60/180				
				I	L	H		
				62	60	180		
PROVA TEST	CARICO PRINCIPALE MAIN POWER LOAD W	CARICO SECONDARIO MINOR POWER LOAD W	VENTOLA 1 FAN 1 TYPE 60x60x25 DC	VENTOLA 2 FAN 2 TYPE 60x60x25 DC	$\Delta T$ °C	RT °C/W	VELOCITA' USCITA ARIA OUTGOING AIR SPEED m/sec	D.D.P. mm H <sub>2</sub> O
1	225	167	*	*	33.0	0.0842	7.5	
2	225		*	*	23.5	0.1044	7.5	
3	225		*	*	27.0	0.1200	5.0	3.0
4	225	167	*	*	38.5	0.098	5.0	3.0

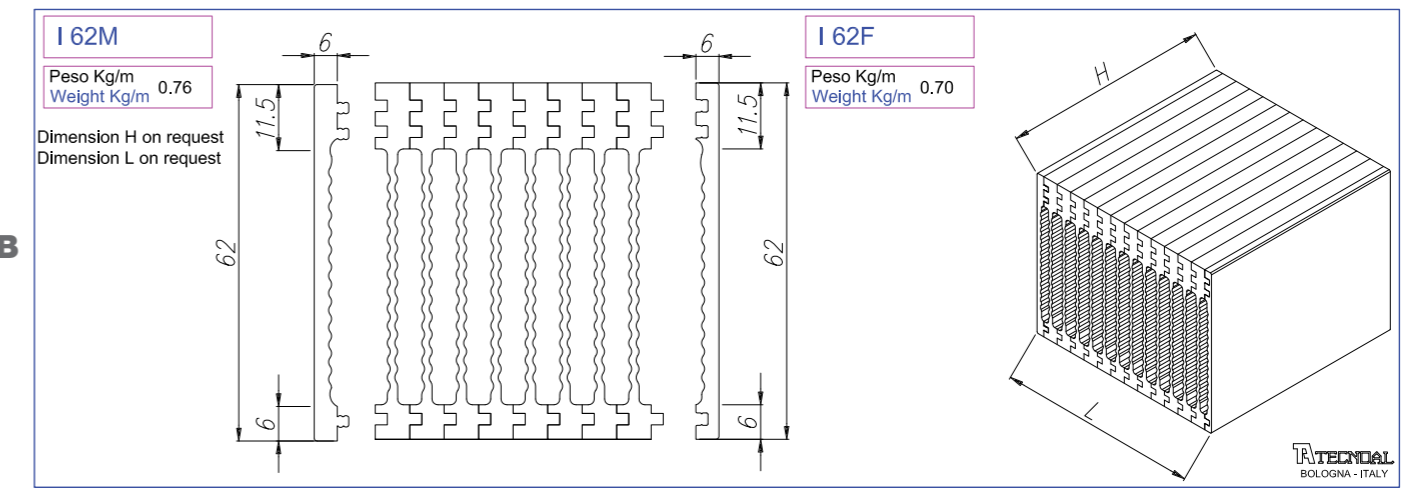

I 62M		Peso Kg/m Weight Kg/m 0.76		Dimension H on request Dimension L on request	
I 62F		Peso Kg/m Weight Kg/m 0.70		Dimension H on request Dimension L on request	



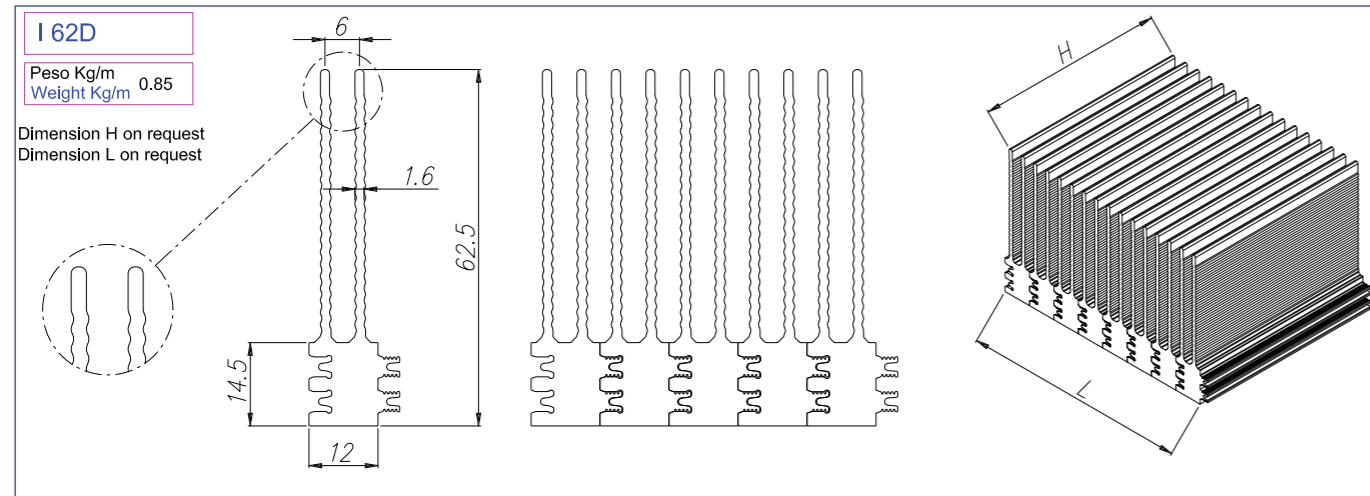

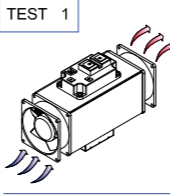
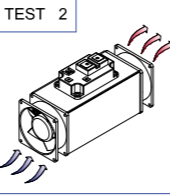
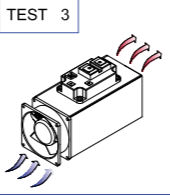
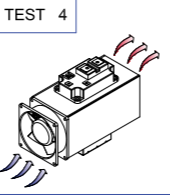
DATA SHEET		PART NUMBER		I 62Dx60/180		I	L	H		
						62	60	180		
PROVA TEST	CARICO PRINCIPALE MAIN POWER LOAD W	CARICO SECONDARIO MINOR POWER LOAD W	VENTOLA 1 FAN 1 TYPE 60x60x25 DC	VENTOLA 2 FAN 2 TYPE 60x60x25 DC	$\Delta T$ °C	RT °C/W	VELOCITA' USCITA ARIA OUTGOING AIR SPEED m/sec	D.D.P. mm H <sub>2</sub> O	   	
2	250		*	*	47.8	0.1912	3.0			
3	250		*	*	50.2	0.2008	2.5	1.6		

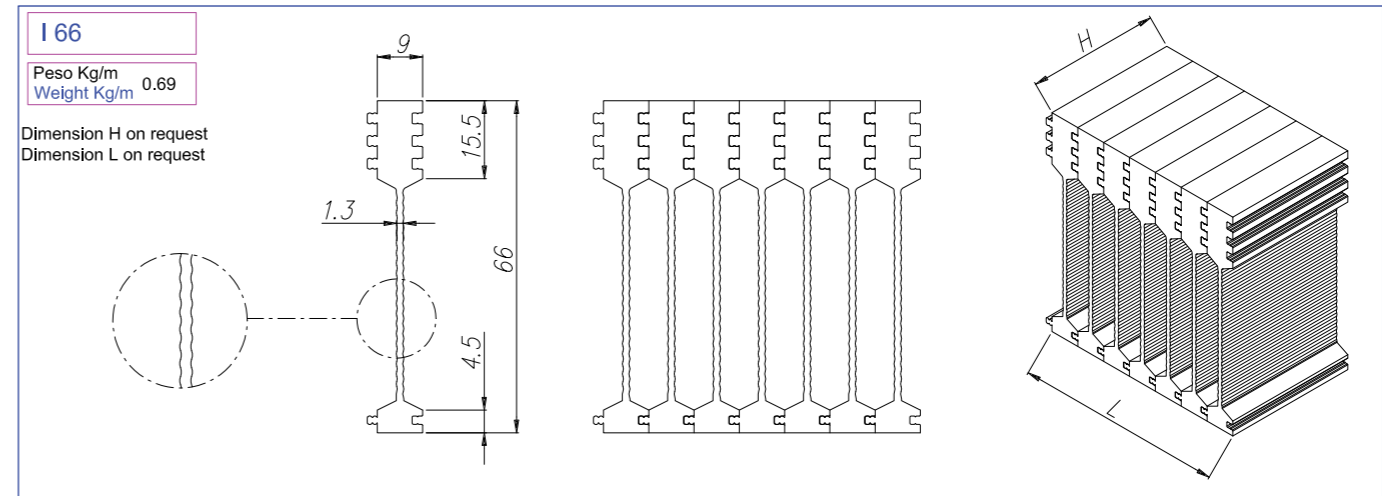

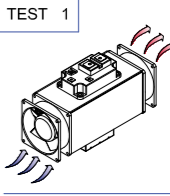
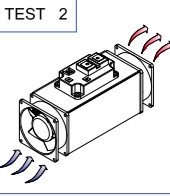
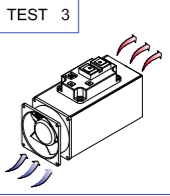
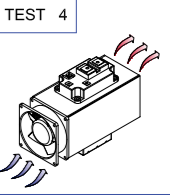
DATA SHEET		PART NUMBER		I 66x60/180		I	L	H		
						66	60	180		
PROVA TEST	CARICO PRINCIPALE MAIN POWER LOAD W	CARICO SECONDARIO MINOR POWER LOAD W	VENTOLA 1 FAN 1 TYPE 60x60x25 DC	VENTOLA 2 FAN 2 TYPE 60x60x25 DC	$\Delta T$ °C	RT °C/W	VELOCITA' USCITA ARIA OUTGOING AIR SPEED m/sec	D.D.P. mm H <sub>2</sub> O	   	
1	225	85	*	*	44.5	0.144	7.0			
2	225		*	*	36.6	0.163	7.0			
3	225		*	*	45.2	0.201	5.0	0.3		
4	225	85	*	*	53.5	0.173	5.0	0.3		

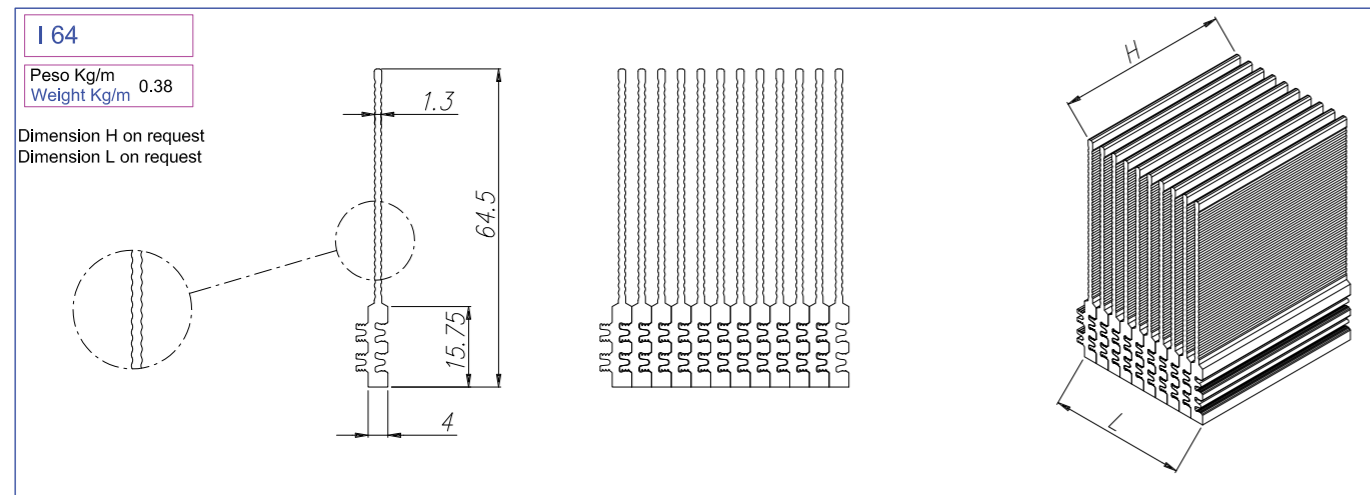

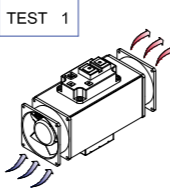
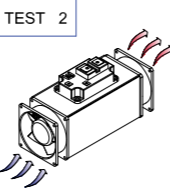
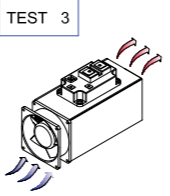
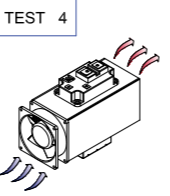
DATA SHEET		PART NUMBER		I 64x60/180		I	L	H		
						64	60	180		
PROVA TEST	CARICO PRINCIPALE MAIN POWER LOAD W	CARICO SECONDARIO MINOR POWER LOAD W	VENTOLA 1 FAN 1 TYPE 60x60x25 DC	VENTOLA 2 FAN 2 TYPE 60x60x25 DC	$\Delta T$ °C	RT °C/W	VELOCITA' USCITA ARIA OUTGOING AIR SPEED m/sec	D.D.P. mm H <sub>2</sub> O	   	
2	225		*	*	30.2	0.1342	6.5			
3	225		*	*	35.3	0.1569	4.5	1.9		

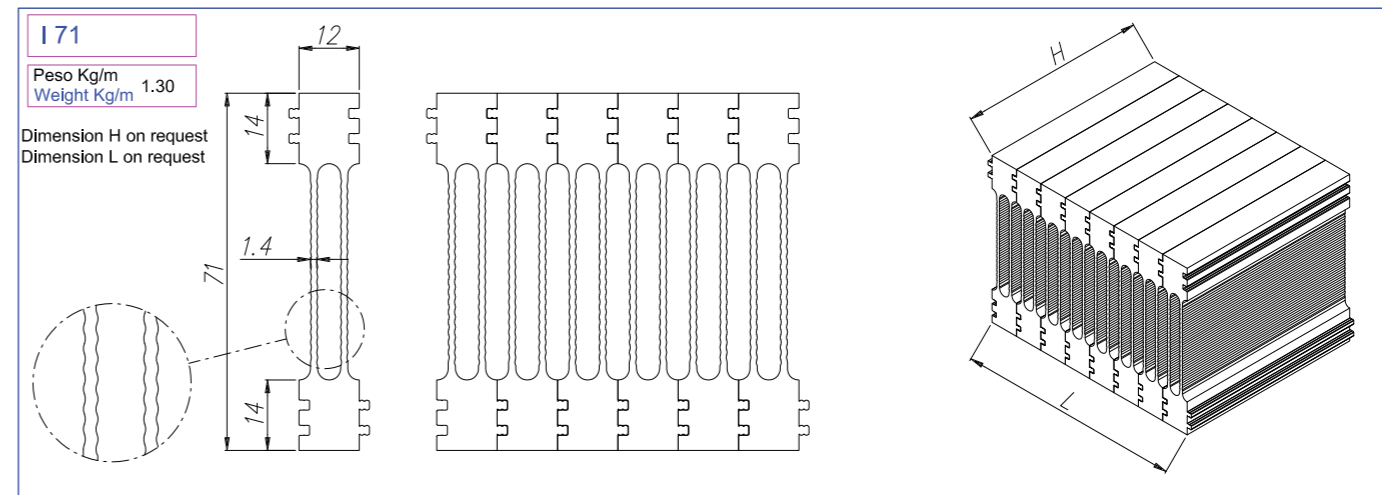

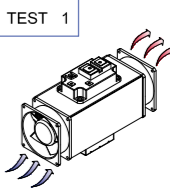
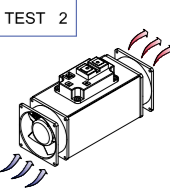
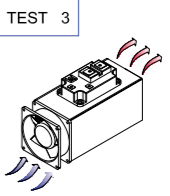
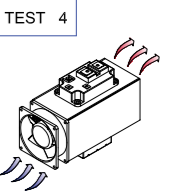
DATA SHEET		PART NUMBER		I 71x60/180		I	L	H		
						71	60	180		
PROVA TEST	CARICO PRINCIPALE MAIN POWER LOAD W	CARICO SECONDARIO MINOR POWER LOAD W	VENTOLA 1 FAN 1 TYPE 60x60x25 DC	VENTOLA 2 FAN 2 TYPE 60x60x25 DC	$\Delta T$ °C	RT °C/W	VELOCITA' USCITA ARIA OUTGOING AIR SPEED m/sec	D.D.P. mm H <sub>2</sub> O	   	
1	250	250	*	*	80.5	0.1610	5.0			
2	360		*	*	71	0.1972	5.0			
3	360		*	*	73	0.2028	4.5	0.8		
4	250	250	*	*	82	0.1640	4.5	0.8		



**I 71MF**  
 Peso Kg/m 0.45  
 Weight Kg/m

Dimension H on request  
 Dimension L on request

**ATECNOAL**  
BOLOGNA - ITALY

**I 71T**  
 Peso Kg/m 0.60  
 Weight Kg/m

Dimension H on request  
 Dimension L on request

DESIGNED FOR VERY CONCENTRATED LOAD

**ATECNOAL**  
BOLOGNA - ITALY

DATA SHEET		PART NUMBER		I		L		H	
		I 71T x 60/180		71	60	180			
PROVA TEST	CARICO PRINCIPALE MAIN POWER LOAD W	CARICO SECONDARIO MINOR POWER LOAD W	VENTOLA 1 FAN 1 TYPE 60x60x25 DC	VENTOLA 2 FAN 2 TYPE 60x60x25 DC	$\Delta T$ °C	RT °C/W	VELOCITA' USCITA ARIA OUTGOING AIR SPEED m/sec	D.D.P. mm H <sub>2</sub> O	
1	250	160	*	*	63.5	0.1549	4.5		TEST 1
2	250		*	*	45	0.1800	4.5		TEST 2
3	250		*	*	51	0.2040	4.0	1.55	TEST 3
4	250	160	*	*	67	0.1634	4.0	1.55	TEST 4

**ATECNOAL**  
BOLOGNA - ITALY

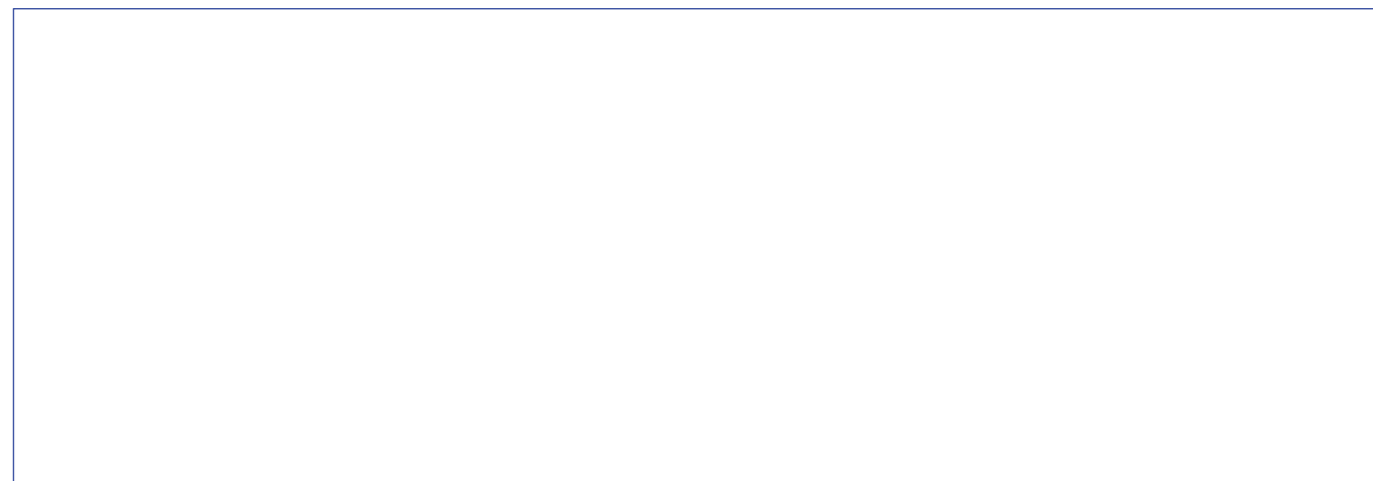

**I 75**  
 Peso Kg/m 0.51  
 Weight Kg/m

Dimension H on request  
 Dimension L on request

**ATECNOAL**  
BOLOGNA - ITALY

DATA SHEET		PART NUMBER		I		L		H	
		I 75x84/170		75	84	170			
PROVA TEST	CARICO PRINCIPALE MAIN POWER LOAD W	CARICO SECONDARIO MINOR POWER LOAD W	VENTOLA 1 FAN 1 TYPE 80x80x25 DC	VENTOLA 2 FAN 2 TYPE 80x80x25 DC	$\Delta T$ °C	RT °C/W	VELOCITA' USCITA ARIA OUTGOING AIR SPEED m/sec	D.D.P. mm H <sub>2</sub> O	
1	450	100	*	*	63.5	0.1154	5.0		TEST 1
2	450		*	*	55.5	0.1233	5.0		TEST 2
3	450		*	*	67	0.1488	3.5	1.2	TEST 3
4	450	64	*	*	73	0.1420	3.5	1.2	TEST 4

**ATECNOAL**  
BOLOGNA - ITALY

**I 75A**  
 Peso Kg/m 0.56  
 Weight Kg/m

Dimension H on request  
 Dimension L on request

**ATECNOAL**  
BOLOGNA - ITALY

DATA SHEET		PART NUMBER		I		L		H	
		I 75Ax84/170		75	84	180			
PROVA TEST	CARICO PRINCIPALE MAIN POWER LOAD W	CARICO SECONDARIO MINOR POWER LOAD W	VENTOLA 1 FAN 1 TYPE 80x80x25 DC	VENTOLA 2 FAN 2 TYPE 80x80x25 DC	$\Delta T$ °C	RT °C/W	VELOCITA' USCITA ARIA OUTGOING AIR SPEED m/sec	D.D.P. mm H <sub>2</sub> O	
1	450	100	*	*	65.5	0.119	5.0		TEST 1
2	450		*	*	57	0.126	5.0		TEST 2
3	450		*	*	68	0.151	3.5	1.4	TEST 3
4	450	64	*	*	74.5	0.144	3.5	1.4	TEST 4

**ATECNOAL**  
BOLOGNA - ITALY

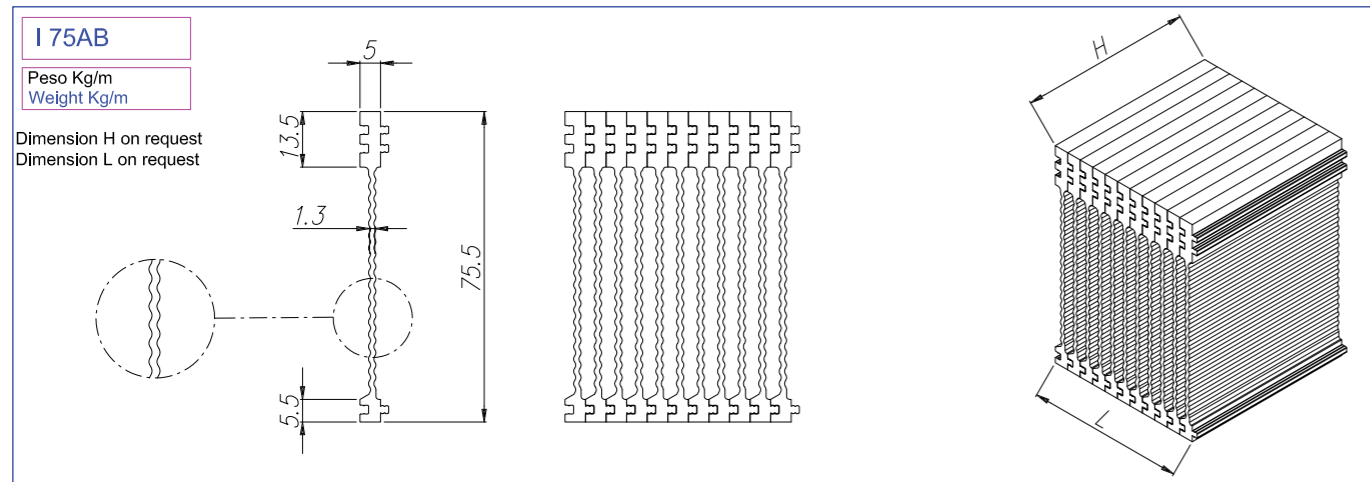

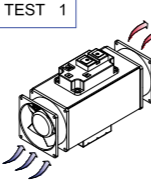
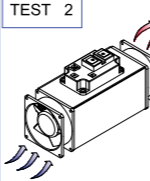
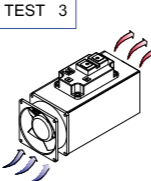
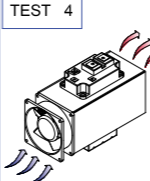
DATA SHEET		PART NUMBER		I 75ABx84/180		I	L	H		
						75	84	180		
PROVA TEST	CARICO PRINCIPALE MAIN POWER LOAD W	CARICO SECONDARIO MINOR POWER LOAD W	VENTOLA 1 FAN 1 TYPE 80x80x25 DC	VENTOLA 2 FAN 2 TYPE 80x80x25 DC	ΔT °C	RT °C/W	VELOCITA' USCITA ARIA OUTGOING AIR SPEED m/sec	D.D.P. mm H <sub>2</sub> O	   	
1	360	160	*	*	38.0	0.0731	7.5			
2	360		*	*	30.2	0.083	7.5			
3	360		*	*	36.1	0.10	5.0	1.5		
4	360	160	*	*	45.8	0.088	5.0	1.5		



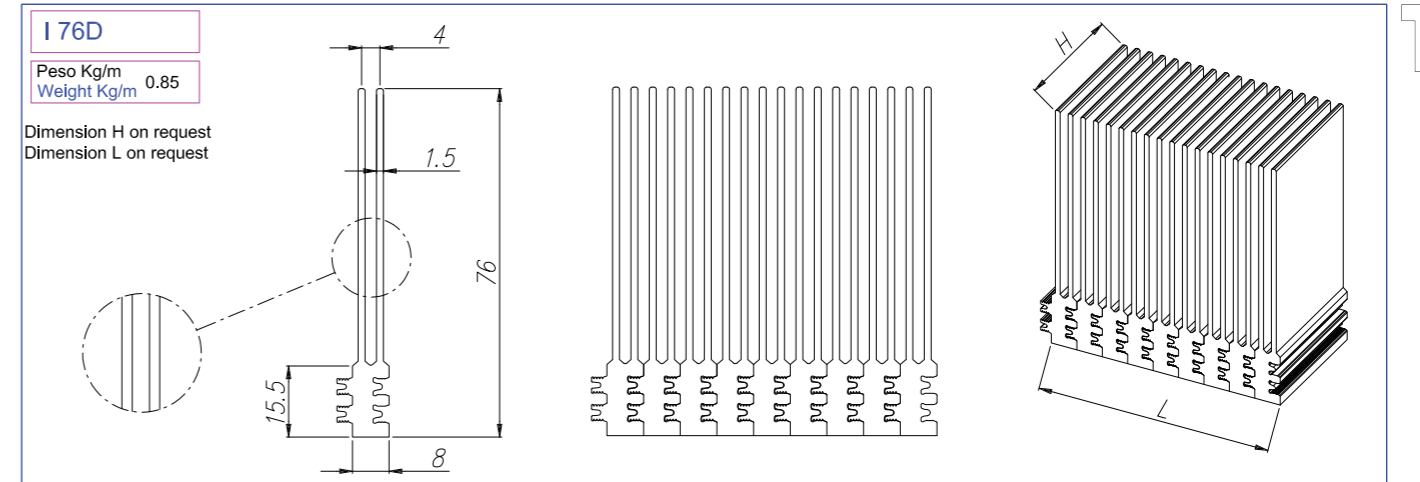

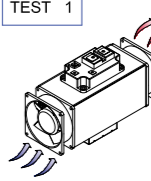
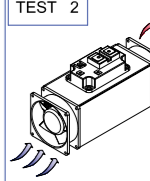
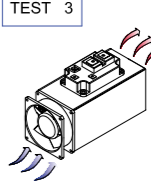
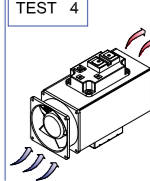
A

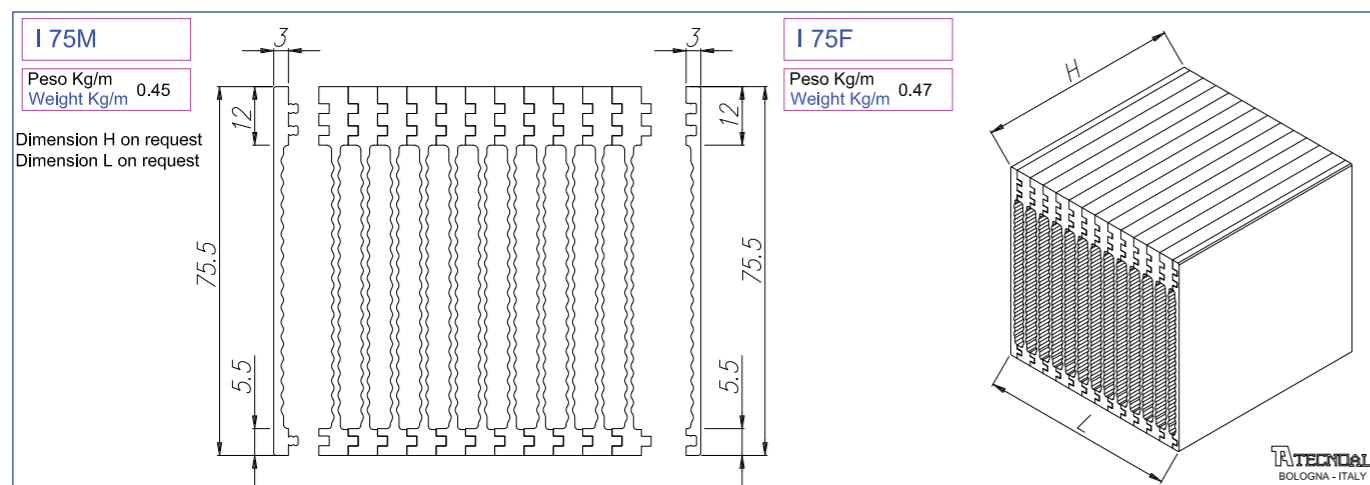

DATA SHEET		PART NUMBER		I 76Dx80/180		I	L	H		
						76	80	180		
PROVA TEST	CARICO PRINCIPALE MAIN POWER LOAD W	CARICO SECONDARIO MINOR POWER LOAD W	VENTOLA 1 FAN 1 TYPE 80x80x25 DC	VENTOLA 2 FAN 2 TYPE 80x80x25 DC	ΔT °C	RT °C/W	VELOCITA' USCITA ARIA OUTGOING AIR SPEED m/sec	D.D.P. mm H <sub>2</sub> O	   	
2	360		*	*	27	0.0750	7.5			
3	360		*	*	31	0.0861	5.0	2.5		

A



DATA SHEET		PART NUMBER		I 75Mx84/180		I	L	H		
						75	84	180		
PROVA TEST	CARICO PRINCIPALE MAIN POWER LOAD W	CARICO SECONDARIO MINOR POWER LOAD W	VENTOLA 1 FAN 1 TYPE 80x80x25 DC	VENTOLA 2 FAN 2 TYPE 80x80x25 DC	ΔT °C	RT °C/W	VELOCITA' USCITA ARIA OUTGOING AIR SPEED m/sec	D.D.P. mm H <sub>2</sub> O	   	
1	360	160	*	*	41.0	0.0788	7.5			
2	360		*	*	33.0	0.0917	7.5			
3	360		*	*	39.0	0.1083	5.0	1.9		
4	360	160	*	*	48.5	0.0933	5.0	1.9		

B

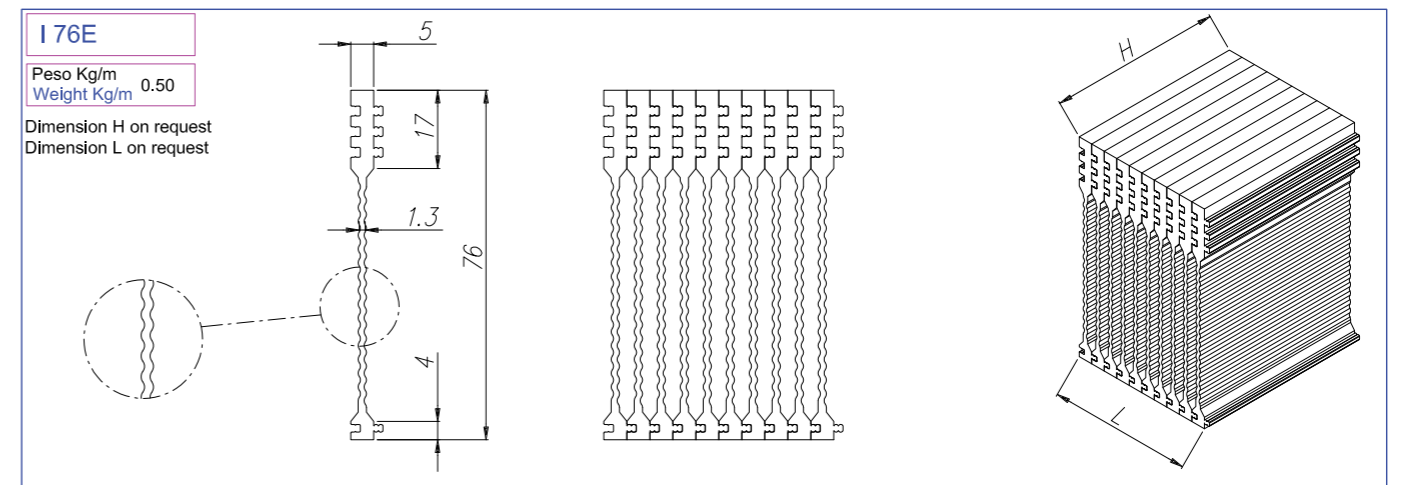

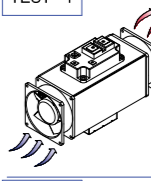
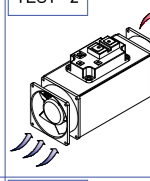
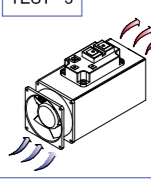
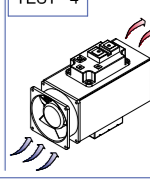
DATA SHEET		PART NUMBER		I 76E8/180		I	L	H		
						76	80	180		
PROVA TEST	CARICO PRINCIPALE MAIN POWER LOAD W	CARICO SECONDARIO MINOR POWER LOAD W	VENTOLA 1 FAN 1 TYPE 80x80x25 DC	VENTOLA 2 FAN 2 TYPE 80x80x25 DC	ΔT °C	RT °C/W	VELOCITA' USCITA ARIA OUTGOING AIR SPEED m/sec	D.D.P. mm H <sub>2</sub> O	   	
1	360	160	*	*	41.0	0.0788	7.5			
2	360		*	*	33.0	0.0917	7.5			
3	360		*	*	39.0	0.1083	5.0	1.9		
4	360	160	*	*	48.5	0.0933	5.0	1.9		

B

**I 76EF**

Peso Kg/m 0.72  
Weight Kg/m

Dimension H on request  
Dimension L on request

**I 76EM**

Peso Kg/m 0.81  
Weight Kg/m

**I 77**

Peso Kg/m 0.50  
Weight Kg/m

Dimension H on request  
Dimension L on request

PROVA TEST	CARICO PRINCIPALE MAIN POWER LOAD W	CARICO SECONDARIO MINOR POWER LOAD W	VENTOLA 1 FAN 1 TYPE 80x80x25 DC	VENTOLA 2 FAN 2 TYPE 80x80x25 DC	I		L		H		VELOCITA' USCITA ARIA OUTGOING AIR SPEED m/sec	D.D.P. mm H <sub>2</sub> O
					77	80	180	77	80	180		
1	360	140	*	*	43.5	0.0870	7.0					
2	360		*	*	36.8	0.1022	7.0					
3	360		*	*	41.3	0.1147	5.0	2.0				
4	360	140	*	*	51.2	0.1024	5.0	2.0				

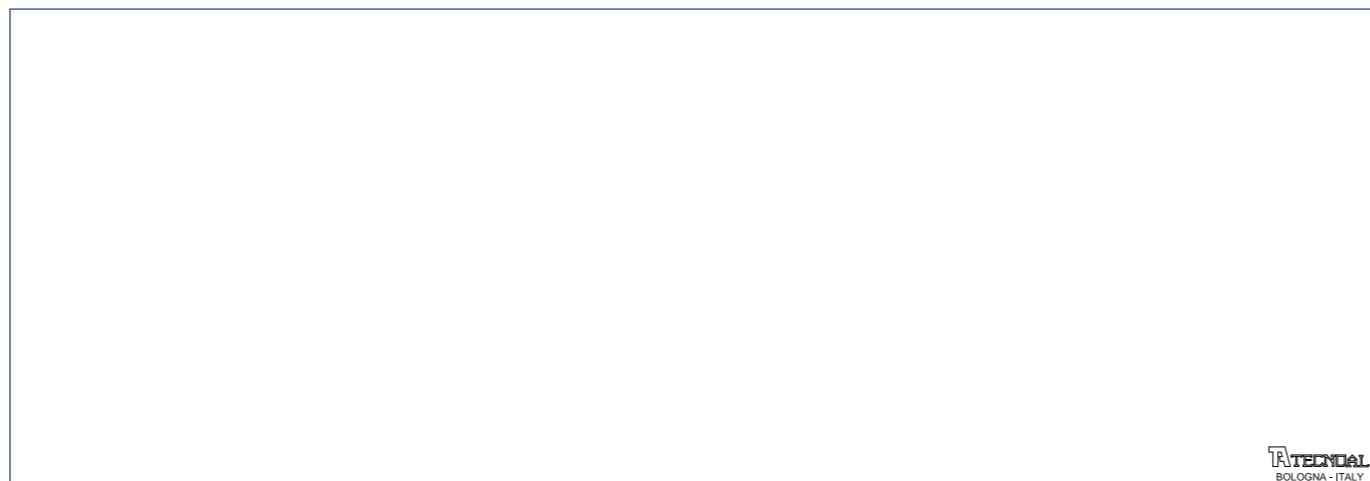

**I 78**

Peso Kg/m 0.39  
Weight Kg/m

Dimension H on request  
Dimension L on request

PROVA TEST	CARICO PRINCIPALE MAIN POWER LOAD W	CARICO SECONDARIO MINOR POWER LOAD W	VENTOLA 1 FAN 1 TYPE 80x80x25 DC	VENTOLA 2 FAN 2 TYPE 80x80x25 DC	I		L		H		VELOCITA' USCITA ARIA OUTGOING AIR SPEED m/sec	D.D.P. mm H <sub>2</sub> O
					77	80	180	77	80	180		
1	360	160	*	*	34.5	0.0663	7.5					
2	360		*	*	27.0	0.0750	7.5					
3	360		*	*	32.0	0.0889	5.0	0.8				
4	360	160	*	*	41.3	0.0794	5.0	0.8				

**I 80**

Peso Kg/m 0.53  
Weight Kg/m

Dimension H on request  
Dimension L on request

PROVA TEST	CARICO PRINCIPALE MAIN POWER LOAD W	CARICO SECONDARIO MINOR POWER LOAD W	VENTOLA 1 FAN 1 TYPE 80x80x25 DC	VENTOLA 2 FAN 2 TYPE 80x80x25 DC	I		L		H		VELOCITA' USCITA ARIA OUTGOING AIR SPEED m/sec	D.D.P. mm H <sub>2</sub> O
					80	80	180	80	80	180		
1	360	360	*	*	63.0	0.0875	8.5					
2	360		*	*	45.0	0.1250	8.5					
3	360		*	*	50.0	0.1389	7.0	5.5				
4	360	360	*	*	71.0	0.0986	7.0	5.5				

**I 80A**  
 Peso Kg/m 0.68  
 Weight Kg/m

Dimension H on request  
 Dimension L on request

DATA SHEET	PART NUMBER	I 80Ax80/180		
		I	L	H
		80	80	180

PROVA TEST	CARICO PRINCIPALE MAIN POWER LOAD W	CARICO SECONDARIO MINOR POWER LOAD W	VENTOLA 1 FAN 1 TYPE 80x80x25 DC	VENTOLA 2 FAN 2 TYPE 80x80x25 DC	ΔT °C	RT °C/W	VELOCITA' USCITA ARIA OUTGOING AIR SPEED m/sec	D.D.P. mm H <sub>2</sub> O
1	225	225	*	*	26.5	0.0589	7.5	
2	225		*	*	17.0	0.0756	7.5	
3	225		*	*	20.0	0.0889	5.0	2.8
4	225	225	*	*	33.0	0.0733	5.0	2.8

TECNOAL BOLOGNA - ITALY

**I 81**  
 Peso Kg/m 0.65  
 Weight Kg/m

Dimension H on request  
 Dimension L on request

DATA SHEET	PART NUMBER	I 81x80/180		
		I	L	H
		81	80	150

PROVA TEST	CARICO PRINCIPALE MAIN POWER LOAD W	CARICO SECONDARIO MINOR POWER LOAD W	VENTOLA 1 FAN 1 TYPE 80x80x25 DC	VENTOLA 2 FAN 2 TYPE 80x80x25 DC	ΔT °C	RT °C/W	VELOCITA' USCITA ARIA OUTGOING AIR SPEED m/sec	D.D.P. mm H <sub>2</sub> O
1	360	160	*	*	51.5	0.0990	7.0	
2	360		*	*	42.5	0.1181	7.0	
3	360		*	*	48.5	0.1347	5.0	2.5
4	360	160	*	*	59.0	0.1135	5.0	2.5

TECNOAL BOLOGNA - ITALY

**I 80MF**  
 Peso Kg/m 0.65  
 Weight Kg/m

Dimension H on request  
 Dimension L on request

TECNOAL BOLOGNA - ITALY

**I 84**  
 Peso Kg/m 0.54  
 Weight Kg/m

Dimension H on request  
 Dimension L on request

DATA SHEET	PART NUMBER	I 84x84/170		
		I	L	H
		84	84	170

PROVA TEST	CARICO PRINCIPALE MAIN POWER LOAD W	CARICO SECONDARIO MINOR POWER LOAD W	VENTOLA 1 FAN 1 TYPE 80x80x25 DC	VENTOLA 2 FAN 2 TYPE 80x80x25 DC	ΔT °C	RT °C/W	VELOCITA' USCITA ARIA OUTGOING AIR SPEED m/sec	D.D.P. mm H <sub>2</sub> O
1	312	144	*	*	46	0.1008	4.5	
2	450		*	*	51.5	0.1144	4.5	
3	450		*	*	57	0.1266	3.5	1.2
4	312	144	*	*	54	0.1184	3.5	1.2

TECNOAL BOLOGNA - ITALY

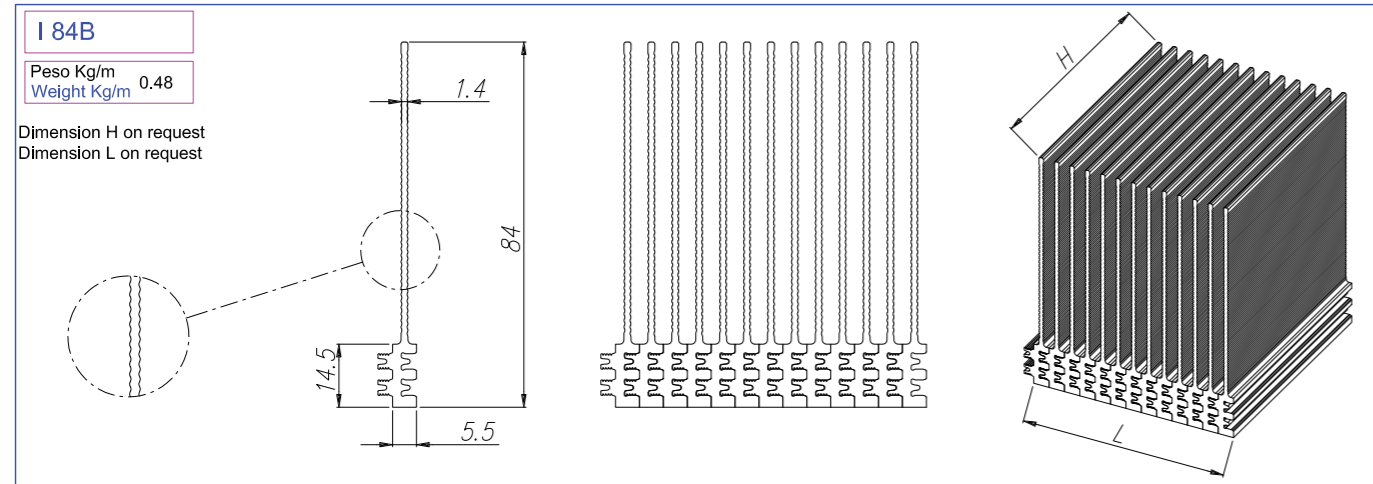

DATA SHEET		PART NUMBER		I 84Bx84/180		I	L	H			
						84	84	180			
PROVA TEST	CARICO PRINCIPALE MAIN POWER LOAD W	CARICO SECONDARIO MINOR POWER LOAD W	VENTOLA 1 FAN 1 TYPE 80x80x25 DC	VENTOLA 2 FAN 2 TYPE 80x80x25 DC	$\Delta T$ °C	RT °C/W	VELOCITA' USCITA ARIA OUTGOING AIR SPEED m/sec	D.D.P. mm H <sub>2</sub> O	TEST 1 TEST 2 TEST 3 TEST 4		
2	420		*	*	41	0.0976	7.5				
3	420		*	*	47	0.1119	5.0	2.2			

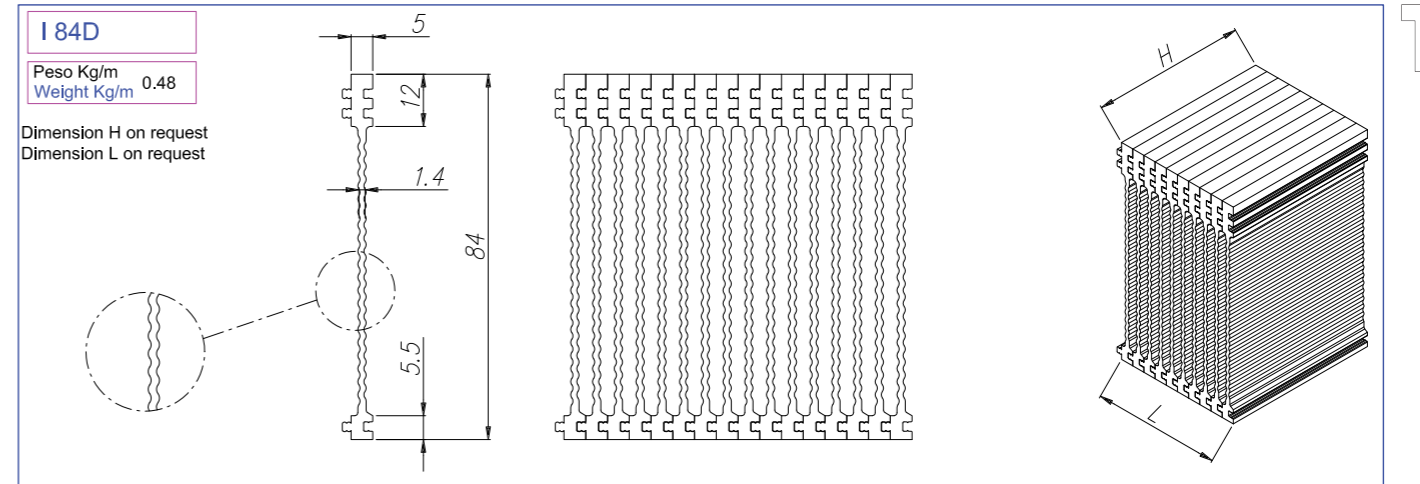

DATA SHEET		PART NUMBER		I 84Dx84/180		I	L	H			
						84	84	180			
PROVA TEST	CARICO PRINCIPALE MAIN POWER LOAD W	CARICO SECONDARIO MINOR POWER LOAD W	VENTOLA 1 FAN 1 TYPE 80x80x25 DC	VENTOLA 2 FAN 2 TYPE 80x80x25 DC	$\Delta T$ °C	RT °C/W	VELOCITA' USCITA ARIA OUTGOING AIR SPEED m/sec	D.D.P. mm H <sub>2</sub> O	TEST 1 TEST 2 TEST 3 TEST 4		
1	360	140	*	*	41.5	0.083	7.0				
2	360		*	*	35.0	0.097	7.0				
3	360		*	*	39.7	0.110	5.0	2.8			
4	360	140	*	*	47.0	0.094	5.0	2.8			

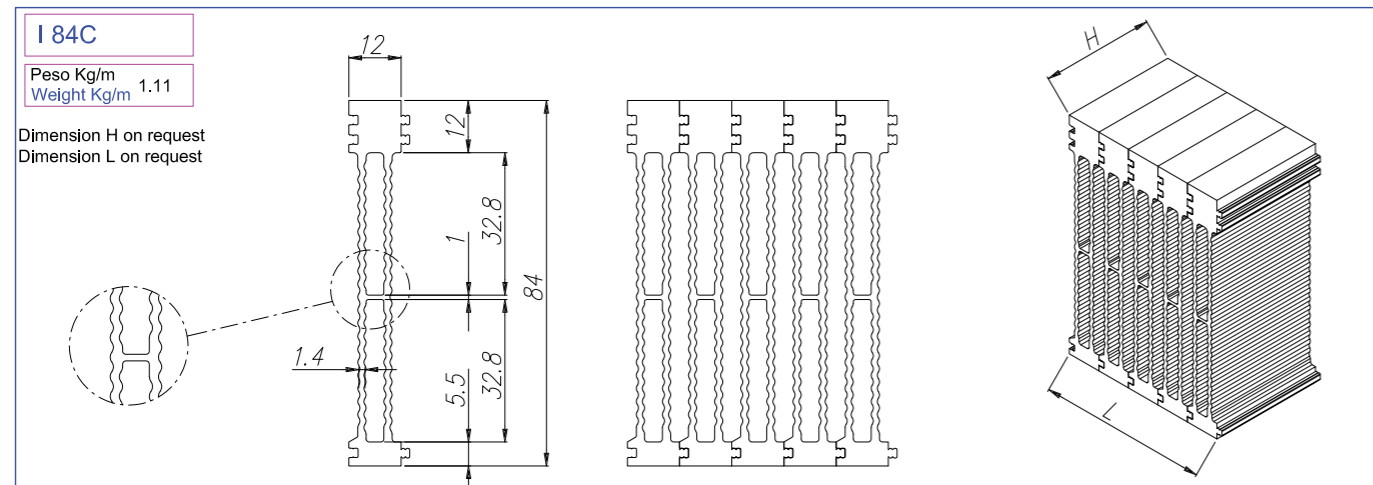

DATA SHEET		PART NUMBER		I 84Cx84/180		I	L	H			
						84	84	180			
PROVA TEST	CARICO PRINCIPALE MAIN POWER LOAD W	CARICO SECONDARIO MINOR POWER LOAD W	VENTOLA 1 FAN 1 TYPE 80x80x25 DC	VENTOLA 2 FAN 2 TYPE 80x80x25 DC	$\Delta T$ °C	RT °C/W	VELOCITA' USCITA ARIA OUTGOING AIR SPEED m/sec	D.D.P. mm H <sub>2</sub> O	TEST 1 TEST 2 TEST 3 TEST 4		
1	360	140	*	*	40.5	0.081	7.0				
2	360		*	*	34.2	0.095	7.0				
3	360		*	*	41.0	0.114	5.0	1.6			
4	360	140	*	*	50.0	0.100	5.0	1.6			

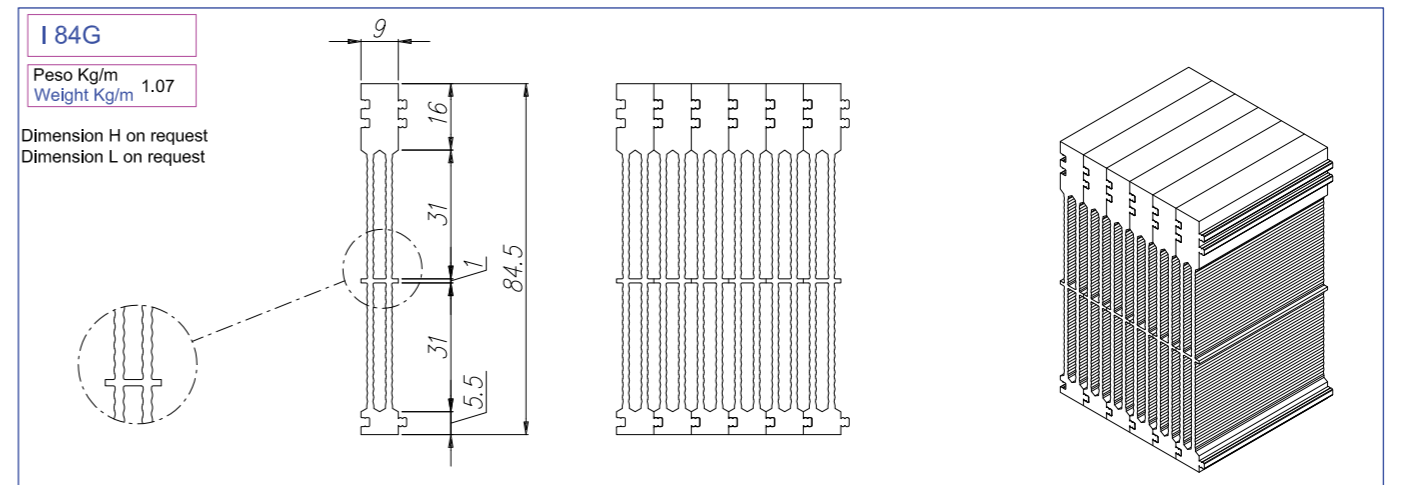

DATA SHEET		PART NUMBER		I 84Gx84/170		I	L	H			
						84	84	170			
PROVA TEST	CARICO PRINCIPALE MAIN POWER LOAD W	CARICO SECONDARIO MINOR POWER LOAD W	VENTOLA 1 FAN 1 TYPE 80x80x25 DC	VENTOLA 2 FAN 2 TYPE 80x80x25 DC	$\Delta T$ °C	RT °C/W	VELOCITA' USCITA ARIA OUTGOING AIR SPEED m/sec	D.D.P. mm H <sub>2</sub> O	TEST 1 TEST 2 TEST 3 TEST 4		
1	360	140	*	*	38.0	0.076	7.0				
2	360		*	*	33.0	0.092	7.0				
3	360		*	*	39.5	0.110	5.0	2.7			
4	360	140	*	*	44.1	0.088	5.0	2.7			



**I 84M**

Peso Kg/m 0.51  
Weight Kg/m

Dimension H on request  
Dimension L on request

**I 84F**

Peso Kg/m 0.53  
Weight Kg/m

A

**I 84FA**

Peso Kg/m 0.58  
Weight Kg/m

Dimension H on request  
Dimension L on request

**I 84MA**

Peso Kg/m 0.58  
Weight Kg/m

B

**I 85B**

Peso Kg/m 0.58  
Weight Kg/m

Dimension H on request  
Dimension L on request

C

PROVA TEST	CARICO PRINCIPALE MAIN POWER LOAD W	CARICO SECONDARIO MINOR POWER LOAD W	VENTOLA 1 FAN 1 TYPE 80x80x25 DC	VENTOLA 2 FAN 2 TYPE 80x80x25 DC	ΔT °C	RT °C/W	VELOCITA' USCITA ARIA OUTGOING AIR SPEED m/sec	D.D.P. mm H <sub>2</sub> O	I 85Bx84/180		
									DATA SHEET	PART NUMBER	
1	360	160	*	*	40.5	0.0779	7.5		85	84	180
2	360		*	*	34.7	0.0964	7.5				
3	360		*		43.0	0.1194	5.0	1.5			
4	360	160	*		47.0	0.1306	5.0	1.5			

TECNOAL BOLOGNA - ITALY

**I 86E**

Peso Kg/m 0.58  
Weight Kg/m

Dimension H on request  
Dimension L on request

A

PROVA TEST	CARICO PRINCIPALE MAIN POWER LOAD W	CARICO SECONDARIO MINOR POWER LOAD W	VENTOLA 1 FAN 1 TYPE 80x80x25 DC	VENTOLA 2 FAN 2 TYPE 80x80x25 DC	ΔT °C	RT °C/W	VELOCITA' USCITA ARIA OUTGOING AIR SPEED m/sec	D.D.P. mm H <sub>2</sub> O	I 86Ex84/180		
									DATA SHEET	PART NUMBER	
1	360	160	*	*	41.2	0.0792	7.5		86	84	180
2	360		*	*	33.7	0.0936	7.5				
3	360		*		39.0	0.1083	5.0	3.2			
4	360	160	*		48.0	0.0923	5.0	3.2			

TECNOAL BOLOGNA - ITALY

**I 86ED**

Peso Kg/m 1.15  
Weight Kg/m

Dimension H on request  
Dimension L on request

B

PROVA TEST	CARICO PRINCIPALE MAIN POWER LOAD W	CARICO SECONDARIO MINOR POWER LOAD W	VENTOLA 1 FAN 1 TYPE 80x80x25 DC	VENTOLA 2 FAN 2 TYPE 80x80x25 DC	ΔT °C	RT °C/W	VELOCITA' USCITA ARIA OUTGOING AIR SPEED m/sec	D.D.P. mm H <sub>2</sub> O	I 86EDx84/180		
									DATA SHEET	PART NUMBER	
1	360	160	*	*	41.2	0.0792	7.5		86	84	180
2	360		*	*	33.7	0.0936	7.5				
3	360		*		39.0	0.1083	5.0	3.2			
4	360	160	*		48.0	0.0923	5.0	3.2			

TECNOAL BOLOGNA - ITALY

**I 90**  
Peso Kg/m 0.61  
Weight Kg/m 0.61

Dimension H on request  
Dimension L on request

DATA SHEET	PART NUMBER	I 90x90/170			I	L	H						
					90	90	180						
PROVA TEST	CARICO PRINCIPALE MAIN POWER LOAD W	CARICO SECONDARIO MINOR POWER LOAD W	VENTOLA 1 FAN 1 TYPE 80x80x25 DC	VENTOLA 2 FAN 2 TYPE 80x80x25 DC	$\Delta T$ °C	RT °C/W	VELOCITA' USCITA ARIA OUTGOING AIR SPEED m/sec	D.D.P. mm H <sub>2</sub> O					
1	450	200	*	*	42	0.0646	6.0						
2	612		*	*	48	0.0784	6.0						
3	612		*	*	56.7	0.0926	4.0	3.0					
4	450	200	*	*	50	0.0796	4.0	3.0					

TEST 1 TEST 2 TEST 3 TEST 4

TECNOAL BOLOGNA - ITALY

**I 91**  
Peso Kg/m 0.68  
Weight Kg/m 0.68

Dimension H on request  
Dimension L on request

DATA SHEET	PART NUMBER	I 91x98/180			I	L	H					
					91	98	180					
PROVA TEST	CARICO PRINCIPALE MAIN POWER LOAD W	CARICO SECONDARIO MINOR POWER LOAD W	VENTOLA 1 FAN 1 TYPE 80x80x25 DC	VENTOLA 2 FAN 2 TYPE 80x80x25 DC	$\Delta T$ °C	RT °C/W	VELOCITA' USCITA ARIA OUTGOING AIR SPEED m/sec	D.D.P. mm H <sub>2</sub> O				
1	360	360	*	*	49	0.0681	7.0					
2	490		*	*	50	0.102	7.0					
3	490		*	*	58	0.118	5.0	1.5				
4	360	360	*	*	60	0.0833	5.0	1.5				

TEST 1 TEST 2 TEST 3 TEST 4

TECNOAL BOLOGNA - ITALY

**I 90M**  
Peso Kg/m 0.57  
Weight Kg/m 0.57

Dimension H on request  
Dimension L on request

**I 90F**  
Peso Kg/m 0.44  
Weight Kg/m 0.44

TECNOAL BOLOGNA - ITALY

**I 91A**  
Peso Kg/m 0.55  
Weight Kg/m 0.55

Dimension H on request  
Dimension L on request

DATA SHEET	PART NUMBER	I 91Ax98/180			I	L	H					
					91	98	180					
PROVA TEST	CARICO PRINCIPALE MAIN POWER LOAD W	CARICO SECONDARIO MINOR POWER LOAD W	VENTOLA 1 FAN 1 TYPE 92x92x38 DC	VENTOLA 2 FAN 2 TYPE 92x92x38 DC	$\Delta T$ °C	RT °C/W	VELOCITA' USCITA ARIA OUTGOING AIR SPEED m/sec	D.D.P. mm H <sub>2</sub> O				
1	360	324	*	*	31.5	0.045	10					
2	360		*	*	23.5	0.065	10					
3	360		*	*	28.5	0.079	6.0	2.5				
4	360	324	*	*	42.0	0.061	6.0	2.5				

TEST 1 TEST 2 TEST 3 TEST 4

TECNOAL BOLOGNA - ITALY

**C**

TECNOAL BOLOGNA - ITALY



**I 91MF**  
 Peso Kg/m 0.94  
 Weight Kg/m

Dimension H on request  
 Dimension L on request

**ATECNOAL**  
BOLOGNA - ITALY

**I 93**  
 Peso Kg/m 0.55  
 Weight Kg/m

Dimension H on request  
 Dimension L on request

**ATECNOAL**  
BOLOGNA - ITALY

DATA SHEET	PART NUMBER	I 93x92/180			I	L	H		
					93	92	180		
PROVA TEST	CARICO PRINCIPALE MAIN POWER LOAD W	CARICO SECONDARIO MINOR POWER LOAD W	VENTOLA 1 FAN 1 TYPE 92x92x38 DC	VENTOLA 2 FAN 2 TYPE 92x92x38 DC	ΔT °C	RT °C/W	VELOCITA' USCITA ARIA OUTGOING AIR SPEED m/sec	D.D.P. mm H <sub>2</sub> O	
1	360	360	*	*	41	0.057	7.0		TEST 1
2	490		*	*	39	0.08	7.0		TEST 2
3	490		*	*	44	0.09	5.0	2.2	TEST 3
4	360	360	*	*	51	0.07	5.0	2.2	TEST 4

**ATECNOAL**  
BOLOGNA - ITALY

**ATECNOAL**  
BOLOGNA - ITALY

**I 98T**  
 Peso Kg/m 0.75  
 Weight Kg/m

Dimension H on request  
 Dimension L on request

DESIGNED FOR VERY CONCENTRATED LOAD

**ATECNOAL**  
BOLOGNA - ITALY

DATA SHEET	PART NUMBER	I 98x92/180			I	L	H		
					98	92	180		
PROVA TEST	CARICO PRINCIPALE MAIN POWER LOAD W	CARICO SECONDARIO MINOR POWER LOAD W	VENTOLA 1 FAN 1 TYPE 92x92x38 DC	VENTOLA 2 FAN 2 TYPE 92x92x38 DC	ΔT °C	RT °C/W	VELOCITA' USCITA ARIA OUTGOING AIR SPEED m/sec	D.D.P. mm H <sub>2</sub> O	
1	360	250	*	*	49	0.0803	6.0		TEST 1
2	360		*	*	37	0.1028	6.0		TEST 2
3	360		*	*	45	0.1250	4.5	2.2	TEST 3
4	360	250	*	*	55.5	0.0910	4.5	2.2	TEST 4

**ATECNOAL**  
BOLOGNA - ITALY

**I 100A**  
 Peso Kg/m 0.54  
 Weight Kg/m

Dimension H on request  
 Dimension L on request

**ATECNOAL**  
BOLOGNA - ITALY

DATA SHEET	PART NUMBER	I 100Ax92/180			I	L	H		
					100	92	180		
PROVA TEST	CARICO PRINCIPALE MAIN POWER LOAD W	CARICO SECONDARIO MINOR POWER LOAD W	VENTOLA 1 FAN 1 TYPE 92x92x38 DC	VENTOLA 2 FAN 2 TYPE 92x92x38 DC	ΔT °C	RT °C/W	VELOCITA' USCITA ARIA OUTGOING AIR SPEED m/sec	D.D.P. mm H <sub>2</sub> O	
1	490	160	*	*	36.5	0.0562	7.5		TEST 1
2	490		*	*	30.5	0.0622	7.5		TEST 2
3	490		*	*	35.5	0.0724	5.0	1.2	TEST 3
4	490	160	*	*	42.5	0.0654	5.0	1.2	TEST 4

**ATECNOAL**  
BOLOGNA - ITALY

**I 100CA**  
 Peso Kg/m 1.13  
 Weight Kg/m

Dimension H on request  
 Dimension L on request

DATA SHEET	PART NUMBER	I 100CAx92/180			I	L	H				
					100	92	180				
PROVA TEST	CARICO PRINCIPALE MAIN POWER LOAD W	CARICO SECONDARIO MINOR POWER LOAD W	VENTOLA 1 FAN 1 TYPE 92x92x38 DC	VENTOLA 2 FAN 2 TYPE 92x92x38 DC	$\Delta T$ °C	RT °C/W	VELOCITA' USCITA ARIA OUTGOING AIR SPEED m/sec	D.D.P. mm H <sub>2</sub> O	TEST 1		
1	490	160	*	*	36.5	0.0562	7.5		TEST 2		
2	490		*	*	30.5	0.0622	7.5		TEST 3		
3	490		*		35.5	0.0724	5.0	1.2	TEST 4		
4	490	160	*		42.5	0.0654	5.0	1.2			

TECNOAL BOLOGNA - ITALY

**I 105A**  
 Peso Kg/m 0.60  
 Weight Kg/m

Dimension H on request  
 Dimension L on request

DATA SHEET	PART NUMBER	I 105Ax92/180			I	L	H				
					105	92	180				
PROVA TEST	CARICO PRINCIPALE MAIN POWER LOAD W	CARICO SECONDARIO MINOR POWER LOAD W	VENTOLA 1 FAN 1 TYPE 92x92x38 DC	VENTOLA 2 FAN 2 TYPE 92x92x38 DC	$\Delta T$ °C	RT °C/W	VELOCITA' USCITA ARIA OUTGOING AIR SPEED m/sec	D.D.P. mm H <sub>2</sub> O	TEST 1		
1	612	225	*	*	46.5	0.0555	6.0		TEST 2		
2	685		*	*	43.8	0.0639	6.0		TEST 3		
3	685		*		51	0.0744	4.0	1.2	TEST 4		
4	612	225	*		55	0.0657	4.0	1.2			

TECNOAL BOLOGNA - ITALY

**I 105**  
 Peso Kg/m 0.65  
 Weight Kg/m

Dimension H on request  
 Dimension L on request

DATA SHEET	PART NUMBER	I 105x92/180			I	L	H				
					105	92	180				
PROVA TEST	CARICO PRINCIPALE MAIN POWER LOAD W	CARICO SECONDARIO MINOR POWER LOAD W	VENTOLA 1 FAN 1 TYPE 92x92x38 DC	VENTOLA 2 FAN 2 TYPE 92x92x38 DC	$\Delta T$ °C	RT °C/W	VELOCITA' USCITA ARIA OUTGOING AIR SPEED m/sec	D.D.P. mm H <sub>2</sub> O	TEST 1		
1	490	360	*	*	55	0.0647	7.1		TEST 2		
2	490		*	*	44	0.089	7.1		TEST 3		
3	490		*		49	0.1000	5.2	1.0	TEST 4		
4	490	360	*		62	0.0729	5.2	1.0			

TECNOAL BOLOGNA - ITALY

**I 105B**  
 Peso Kg/m 0.56  
 Weight Kg/m

Dimension H on request  
 Dimension L on request

DATA SHEET	PART NUMBER	I 105Bx140/300			I	L	H				
					105	140	300				
PROVA TEST	CARICO PRINCIPALE MAIN POWER LOAD W	CARICO SECONDARIO MINOR POWER LOAD W	VENTOLA 1 FAN 1 TYPE 92x92x38 DC	VENTOLA 2 FAN 2 TYPE 92x92x38 DC	$\Delta T$ °C	RT °C/W	VELOCITA' USCITA ARIA OUTGOING AIR SPEED m/sec	D.D.P. mm H <sub>2</sub> O	TEST 1		
1	685	490	*	*	27.5	0.0234	7.0		TEST 2		
2	685		*	*	21	0.0307	7.0		TEST 3		
3	685		*		24	0.0350	5.0	9	TEST 4		
4	685	490	*		35	0.0297	5.0	9			

TECNOAL BOLOGNA - ITALY

**I 105C**  
 Peso Kg/m 1.20  
 Weight Kg/m

Dimension H on request  
 Dimension L on request

DATA SHEET	PART NUMBER	I 105Cx92/180		
		I	L	H
		105	92	180

PROVA TEST	CARICO PRINCIPALE MAIN POWER LOAD W	CARICO SECONDARIO MINOR POWER LOAD W	VENTOLA 1 FAN 1 TYPE 92x92x38 DC	VENTOLA 2 FAN 2 TYPE 92x92x38 DC	ΔT °C	RT °C/W	VELOCITA' USCITA ARIA OUTGOING AIR SPEED m/sec	D.D.P. mm H <sub>2</sub> O
1	612	225	*	*	46.5	0.0555	6.0	
2	685		*	*	43.8	0.0639	6.0	
3	685		*		51	0.0744	4.0	1.2
4	612	225	*		55	0.0657	4.0	1.2

TEST 1 TEST 2 TEST 3 TEST 4

ATECNAL BOLOGNA - ITALY

**I 105M**  
 Peso Kg/m 1.38  
 Weight Kg/m

Dimension H on request  
 Dimension L on request

**I 105F**  
 Peso Kg/m 1.00  
 Weight Kg/m

ATECNAL BOLOGNA - ITALY

**I 117C**  
 Peso Kg/m 1.50  
 Weight Kg/m

Dimension H on request  
 Dimension L on request

DATA SHEET	PART NUMBER	I 117x120/200		
		I	L	H
		117	120	200

PROVA TEST	CARICO PRINCIPALE MAIN POWER LOAD W	CARICO SECONDARIO MINOR POWER LOAD W	VENTOLA 1 FAN 1 TYPE 120x120x40 DC	VENTOLA 2 FAN 2 TYPE 120x120x40 DC	ΔT °C	RT °C/W	VELOCITA' USCITA ARIA OUTGOING AIR SPEED m/sec	D.D.P. mm H <sub>2</sub> O
1	612	200	*	*	40.5	0.0498	6.0	
2	722		*	*	42	0.0581	6.0	
3	722		*		48	0.0664	4.0	1.5
4	612	200	*		47	0.0578	4.0	1.5

TEST 1 TEST 2 TEST 3 TEST 4

ATECNAL BOLOGNA - ITALY

**I 117CA**  
 Peso Kg/m 1.55  
 Weight Kg/m

Dimension H on request  
 Dimension L on request

DATA SHEET	PART NUMBER	I 117CAx120/200		
		I	L	H
		117	120	200

PROVA TEST	CARICO PRINCIPALE MAIN POWER LOAD W	CARICO SECONDARIO MINOR POWER LOAD W	VENTOLA 1 FAN 1 TYPE 120x120x40 DC	VENTOLA 2 FAN 2 TYPE 120x120x40 DC	ΔT °C	RT °C/W	VELOCITA' USCITA ARIA OUTGOING AIR SPEED m/sec	D.D.P. mm H <sub>2</sub> O
1	612	200	*	*	40.5	0.0498	6.0	
2	722		*	*	42	0.0581	6.0	
3	722		*		48	0.0664	4.0	1.5
4	612	200	*		47	0.0578	4.0	1.5

TEST 1 TEST 2 TEST 3 TEST 4

ATECNAL BOLOGNA - ITALY

**I 117F**

Peso Kg/m 1.10  
Weight Kg/m

Dimension H on request  
Dimension L on request

**I 117M**

Peso Kg/m 1.14  
Weight Kg/m

**I 117FA**

Peso Kg/m 1.45  
Weight Kg/m

Dimension H on request  
Dimension L on request

**I 117MA**

Peso Kg/m 1.53  
Weight Kg/m

**I 117MB**

Peso Kg/m 0.98  
Weight Kg/m

Dimension H on request  
Dimension L on request

**I 125**

Peso Kg/m 1.75  
Weight Kg/m

Dimension H on request  
Dimension L on request

DATA SHEET	PART NUMBER	I 125x150/300		
		I	L	H
		125	150	300

PROVA TEST	CARICO PRINCIPALE MAIN POWER LOAD W	CARICO SECONDARIO MINOR POWER LOAD W	VENTOLA 1 FAN 1 TYPE	VENTOLA 2 FAN 2 TYPE	ΔT °C	RT °C/W	VELOCITA' USCITA ARIA OUTGOING AIR SPEED m/sec	D.D.P. mm H <sub>2</sub> O
1	600	215	*	*	33	0.0404	5.0	
2	1350		*	*	62	0.0459	5.0	
3	940		*	*	52.4	0.0557	3.0	3.5
4	940	215	*	*	59.5	0.0515	3.0	3.5

**I 125A**

Peso Kg/m 0.73  
Weight Kg/m

Dimension H on request  
Dimension L on request

DATA SHEET	PART NUMBER	I 125Ax150/300		
		I	L	H
		125	150	300

PROVA TEST	CARICO PRINCIPALE MAIN POWER LOAD W	CARICO SECONDARIO MINOR POWER LOAD W	VENTOLA 1 FAN 1 TYPE	VENTOLA 2 FAN 2 TYPE	ΔT °C	RT °C/W	VELOCITA' USCITA ARIA OUTGOING AIR SPEED m/sec	D.D.P. mm H <sub>2</sub> O
1	940	215	*	*	45	0.0389	5.5	
2	1350		*	*	57.5	0.0425	5.5	
3	940		*	*	47	0.0500	3.5	3.0
4	940	215	*	*	52.5	0.0454	3.5	3.0

**I 125B**  
 Peso Kg/m 2.50  
 Weight Kg/m

Dimension H on request  
 Dimension L on request

DATA SHEET	PART NUMBER	I 125Bx150/300			ΔT	RT	VELOCITA' USCITA ARIA OUTGOING AIR SPEED	D.D.P.
		I	L	H				
		125	150	300				

PROVA TEST	CARICO PRINCIPALE MAIN POWER LOAD W	CARICO SECONDARIO MINOR POWER LOAD W	VENTOLA 1 FAN 1 TYPE 120x120x40 DC	VENTOLA 2 FAN 2 TYPE 120x120x40 DC	ΔT °C	RT °C/W	VELOCITA' USCITA ARIA OUTGOING AIR SPEED m/sec	D.D.P. mm H <sub>2</sub> O
1	600	215	*	*	32.5	0.0389	6.0	
2	1350		*	*	62.3	0.0461	6.0	
3	940		*	*	50.5	0.0537	4.0	2.5
4	940	215	*	*	56	0.0484	4.0	2.5

TEST 1 TEST 2 TEST 3 TEST 4

ATECNAL BOLOGNA - ITALY

**I 125C**  
 Peso Kg/m 3.04  
 Weight Kg/m

Dimension H on request  
 Dimension L on request

DATA SHEET	PART NUMBER	I 125Cx150/300			ΔT	RT	VELOCITA' USCITA ARIA OUTGOING AIR SPEED	D.D.P.
		I	L	H				
		125	150	300				

PROVA TEST	CARICO PRINCIPALE MAIN POWER LOAD W	CARICO SECONDARIO MINOR POWER LOAD W	VENTOLA 1 FAN 1 TYPE 120x120x40 DC	VENTOLA 2 FAN 2 TYPE 120x120x40 DC	ΔT °C	RT °C/W	VELOCITA' USCITA ARIA OUTGOING AIR SPEED m/sec	D.D.P. mm H <sub>2</sub> O
1	600	600	*	*	29	0.0242	10.5	
2	600		*	*	26	0.0433	10.5	
3	600		*	*	28	0.0466	7.0	3.5
4	600	600	*	*	32	0.0267	7.0	3.5

TEST 1 TEST 2 TEST 3 TEST 4

ATECNAL BOLOGNA - ITALY

**I 125D**  
 Peso Kg/m 0.61  
 Weight Kg/m

Dimension H on request  
 Dimension L on request

DATA SHEET	PART NUMBER	I 125Dx150/300			ΔT	RT	VELOCITA' USCITA ARIA OUTGOING AIR SPEED	D.D.P.
		I	L	H				
		125	150	300				

PROVA TEST	CARICO PRINCIPALE MAIN POWER LOAD W	CARICO SECONDARIO MINOR POWER LOAD W	VENTOLA 1 FAN 1 TYPE 120x120x40 DC	VENTOLA 2 FAN 2 TYPE 120x120x40 DC	ΔT °C	RT °C/W	VELOCITA' USCITA ARIA OUTGOING AIR SPEED m/sec	D.D.P. mm H <sub>2</sub> O
1	720	503	*	*	26.0	0.0213	10.0	
2	720		*	*	19.0	0.0264	10.5	
3	720		*	*	22.0	0.0306	4.5	6.5
4	720	503	*	*	29.5	0.0241	4.5	6.5

TEST 1 TEST 2 TEST 3 TEST 4

ATECNAL BOLOGNA - ITALY

**I 125P**  
 Peso Kg/m 1.40  
 Weight Kg/m

Dimension H on request  
 Dimension L on request

DATA SHEET	PART NUMBER	I 125Px150/300			ΔT	RT	VELOCITA' USCITA ARIA OUTGOING AIR SPEED	D.D.P.
		I	L	H				
		125	150	300				

PROVA TEST	CARICO PRINCIPALE MAIN POWER LOAD W	CARICO SECONDARIO MINOR POWER LOAD W	VENTOLA 1 FAN 1 TYPE 120x120x40 DC	VENTOLA 2 FAN 2 TYPE 120x120x40 DC	ΔT °C	RT °C/W	VELOCITA' USCITA ARIA OUTGOING AIR SPEED m/sec	D.D.P. mm H <sub>2</sub> O
1	720	360	*	*	25	0.0231	10.5	
2	980		*	*	28.5	0.0291	10.5	
3	980		*	*	34.5	0.0352	4.5	5.0
4	720	360	*	*	35	0.0324	4.5	5.0

TEST 1 TEST 2 TEST 3 TEST 4

ATECNAL BOLOGNA - ITALY

**I 125Q**  
 Peso Kg/m 1.40  
 Weight Kg/m

Dimension H on request  
 Dimension L on request

DATA SHEET	PART NUMBER	I	L	H
	I 125Qx150/300	125	150	300

PROVA TEST	CARICO PRINCIPALE MAIN POWER LOAD W	CARICO SECONDARIO MINOR POWER LOAD W	VENTOLA 1 FAN 1 TYPE 120x120x40 DC	VENTOLA 2 FAN 2 TYPE 120x120x40 DC	ΔT °C	RT °C/W	VELOCITA' USCITA ARIA OUTGOING AIR SPEED m/sec	D.D.P. mm H <sub>2</sub> O
1	720	503	*	*	30	0.024	8.0	
2	720		*	*	25	0.034	8.0	
3	720		*	*	28	0.038	5.5	17
4	720	503	*	*	32	0.026	5.5	17

TECNOAL BOLOGNA - ITALY

**I 125F**  
 Peso Kg/m 2.05  
 Weight Kg/m

Dimension H on request  
 Dimension L on request

**I 125M**  
 Peso Kg/m 2.10  
 Weight Kg/m

TECNOAL BOLOGNA - ITALY

**I 125FA**  
 Peso Kg/m 2.15  
 Weight Kg/m

Dimension H on request  
 Dimension L on request

**I 125MA**  
 Peso Kg/m 2.17  
 Weight Kg/m

TECNOAL BOLOGNA - ITALY

**I 128**  
 Peso Kg/m 0.90  
 Weight Kg/m

Dimension H on request  
 Dimension L on request

DATA SHEET	PART NUMBER	I	L	H
	I 128x120/200	128	120	200

PROVA TEST	CARICO PRINCIPALE MAIN POWER LOAD W	CARICO SECONDARIO MINOR POWER LOAD W	VENTOLA 1 FAN 1 TYPE 120x120x40 DC	VENTOLA 2 FAN 2 TYPE 120x120x40 DC	ΔT °C	RT °C/W	VELOCITA' USCITA ARIA OUTGOING AIR SPEED m/sec	D.D.P. mm H <sub>2</sub> O
1	450	450	*	*	36	0.0400	6.0	
2	612		*	*	36	0.0588	6.0	
3	612		*	*	40	0.0653	4.3	1.5
4	450	450	*	*	42.5	0.0472	4.3	1.5

TECNOAL BOLOGNA - ITALY

**I 128B**  
 Peso Kg/m 0.90  
 Weight Kg/m

Dimension H on request  
 Dimension L on request

DATA SHEET	PART NUMBER	I	L	H
	I 128Bx120/200	128	120	200

PROVA TEST	CARICO PRINCIPALE MAIN POWER LOAD W	CARICO SECONDARIO MINOR POWER LOAD W	VENTOLA 1 FAN 1 TYPE 120x120x40 DC	VENTOLA 2 FAN 2 TYPE 120x120x40 DC	ΔT °C	RT °C/W	VELOCITA' USCITA ARIA OUTGOING AIR SPEED m/sec	D.D.P. mm H <sub>2</sub> O
1	450	450	*	*	35	0.0390	6.0	
2	612		*	*	35	0.0570	6.0	
3	612		*	*	39.5	0.0640	4.3	1.5
4	450	450	*	*	42.0	0.0460	4.3	1.5

TECNOAL BOLOGNA - ITALY

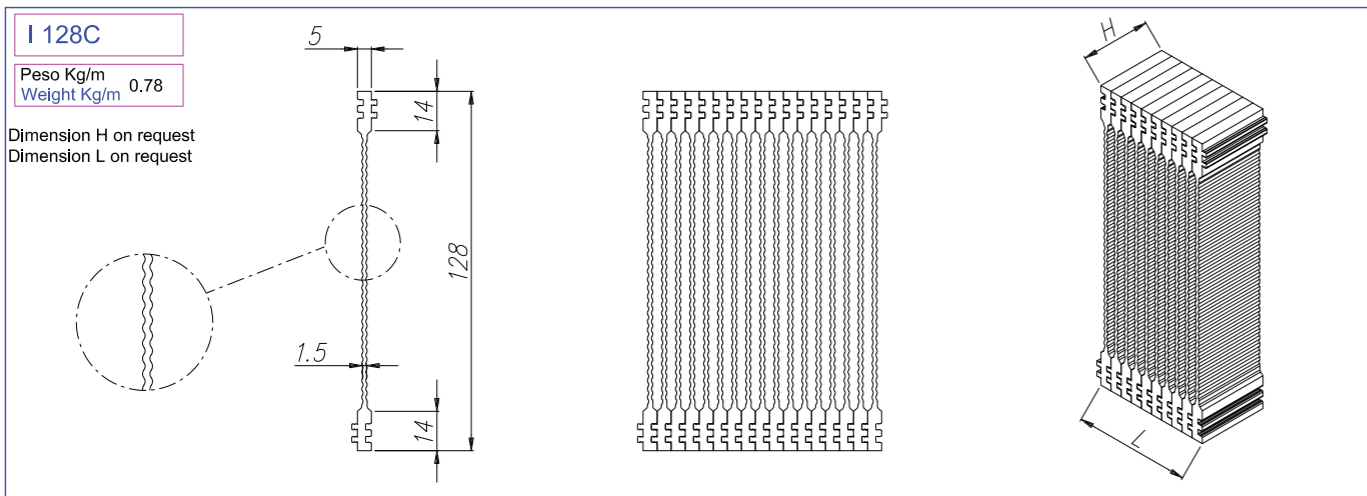

DATA SHEET		PART NUMBER		I 128Cx120/200		I	L	H	TEST 1		TEST 2	
						128	120	200				
PROVA TEST	CARICO PRINCIPALE MAIN POWER LOAD W	CARICO SECONDARIO MINOR POWER LOAD W	VENTOLA 1 FAN 1 TYPE 120x120x40 DC	VENTOLA 2 FAN 2 TYPE 120x120x40 DC	ΔT °C	RT °C/W	VELOCITA' USCITA ARIA OUTGOING AIR SPEED m/sec	D.D.P. mm H <sub>2</sub> O	TEST 3		TEST 4	
1	400	400	*	*	31	0.0389	7.0					
2	400		*	*	32.7	0.0818	7.0					
3	400		*	*	36.3	0.0908	5.0	4.0				
4	400	400	*	*	36	0.0450	5.0	4.0				

A

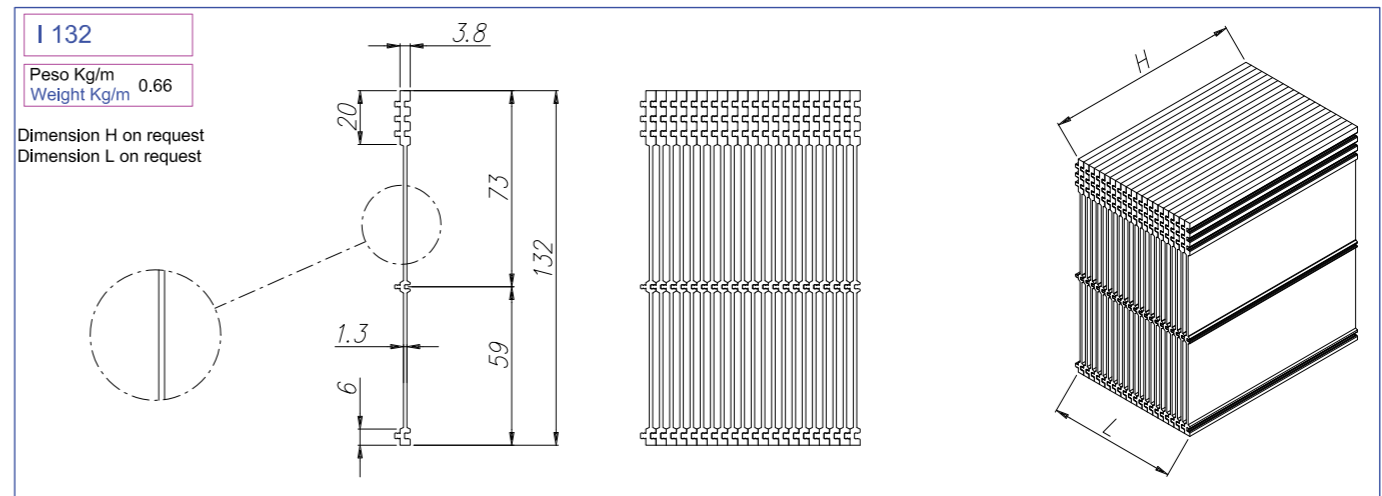

DATA SHEET		PART NUMBER		I 132x150/290		I	L	H	TEST 1		TEST 2	
						132	150	290				
PROVA TEST	CARICO PRINCIPALE MAIN POWER LOAD W	CARICO SECONDARIO MINOR POWER LOAD W	VENTOLA 1 FAN 1 TYPE 120x120x40 DC	VENTOLA 2 FAN 2 TYPE 120x120x40 DC	ΔT °C	RT °C/W	VELOCITA' USCITA ARIA OUTGOING AIR SPEED m/sec	D.D.P. mm H <sub>2</sub> O	TEST 3		TEST 4	
1	600	300	*	*	27.8	0.0309	10.0					
2	720		*	*	22.2	0.0308	10.0					
3	720		*	*	24.2	0.0336	6.5	12				
4	600	300	*	*	24.8	0.0276	6.5	12				

A

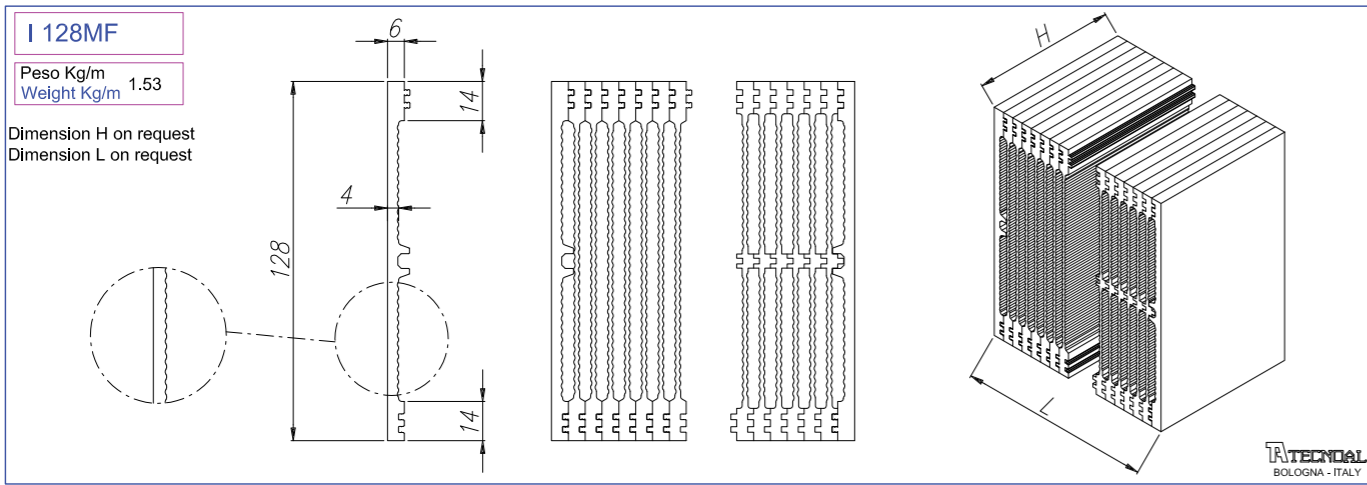

DATA SHEET		PART NUMBER		I 128MFx120/200		I	L	H	TEST 1		TEST 2	
						128	120	200				
PROVA TEST	CARICO PRINCIPALE MAIN POWER LOAD W	CARICO SECONDARIO MINOR POWER LOAD W	VENTOLA 1 FAN 1 TYPE 120x120x40 DC	VENTOLA 2 FAN 2 TYPE 120x120x40 DC	ΔT °C	RT °C/W	VELOCITA' USCITA ARIA OUTGOING AIR SPEED m/sec	D.D.P. mm H <sub>2</sub> O	TEST 3		TEST 4	
1	400	400	*	*	31	0.0389	7.0					
2	400		*	*	32.7	0.0818	7.0					
3	400		*	*	36.3	0.0908	5.0	4.0				
4	400	400	*	*	36	0.0450	5.0	4.0				

B

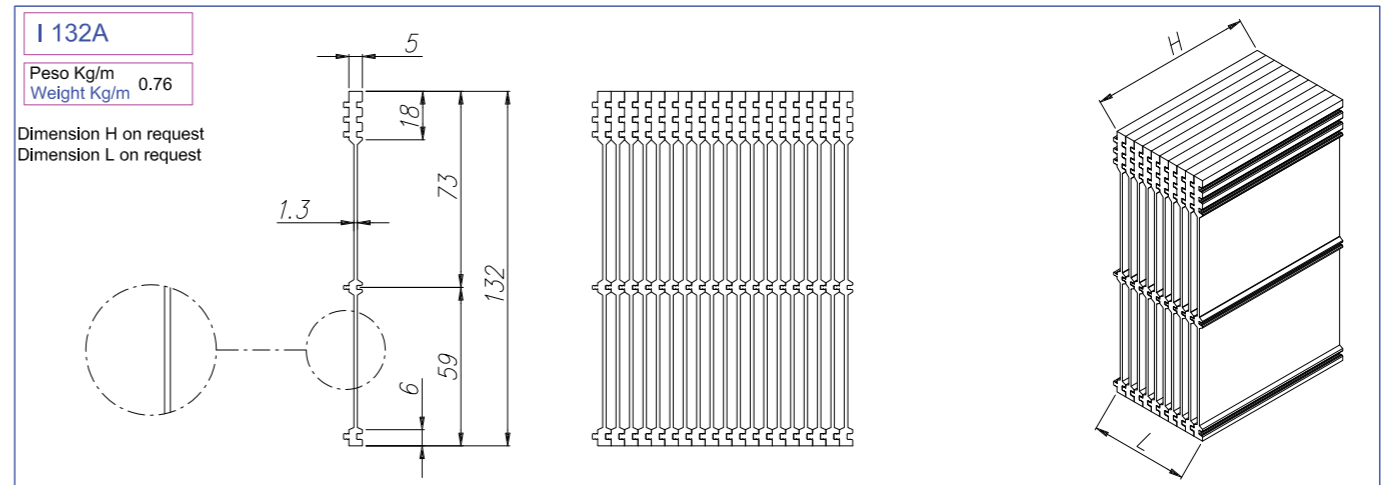

DATA SHEET		PART NUMBER		I 132Ax150/290		I	L	H	TEST 1		TEST 2	
						132	150	290				
PROVA TEST	CARICO PRINCIPALE MAIN POWER LOAD W	CARICO SECONDARIO MINOR POWER LOAD W	VENTOLA 1 FAN 1 TYPE 120x120x40 DC	VENTOLA 2 FAN 2 TYPE 120x120x40 DC	ΔT °C	RT °C/W	VELOCITA' USCITA ARIA OUTGOING AIR SPEED m/sec	D.D.P. mm H <sub>2</sub> O	TEST 3		TEST 4	
1	600	300	*	*	24.7	0.0274	10.0					
2	720		*	*	24.5	0.0340	10.0					
3	720		*	*	25.6	0.0355	6.5	8.0				
4	600	300	*	*	26.2	0.0291	6.5	8.0				

B

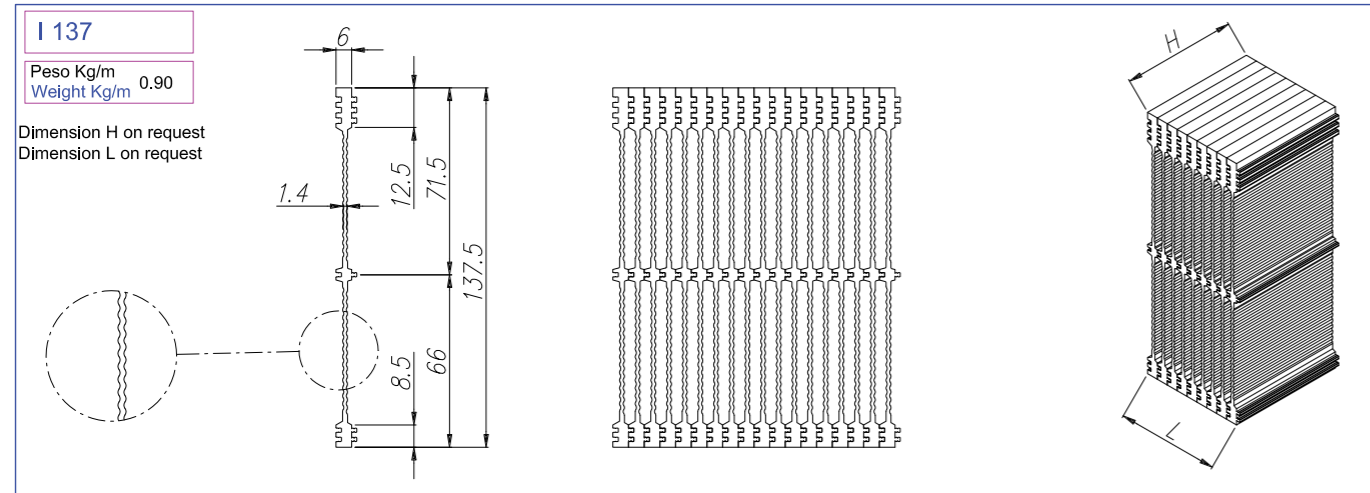

DATA SHEET		PART NUMBER		I 137x150/300		I	L	H		
						137	150	300		
PROVA TEST	CARICO PRINCIPALE MAIN POWER LOAD W	CARICO SECONDARIO MINOR POWER LOAD W	VENTOLA 1 FAN 1 TYPE	VENTOLA 2 FAN 2 TYPE	$\Delta T$ °C	RT °C/W	VELOCITA' USCITA ARIA OUTGOING AIR SPEED m/sec	D.D.P. mm H <sub>2</sub> O		
1	720	503	*	*	29.0	0.0237	10.0			
2	720		*	*	24.3	0.0338	10.0			
3	720		*	*	25.2	0.0350	5.5	3.5		
4	720	503	*	*	34.0	0.0303	5.5	3.5		

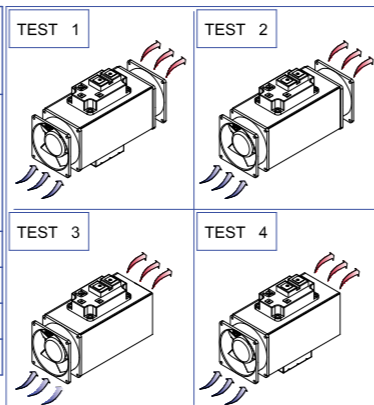

A

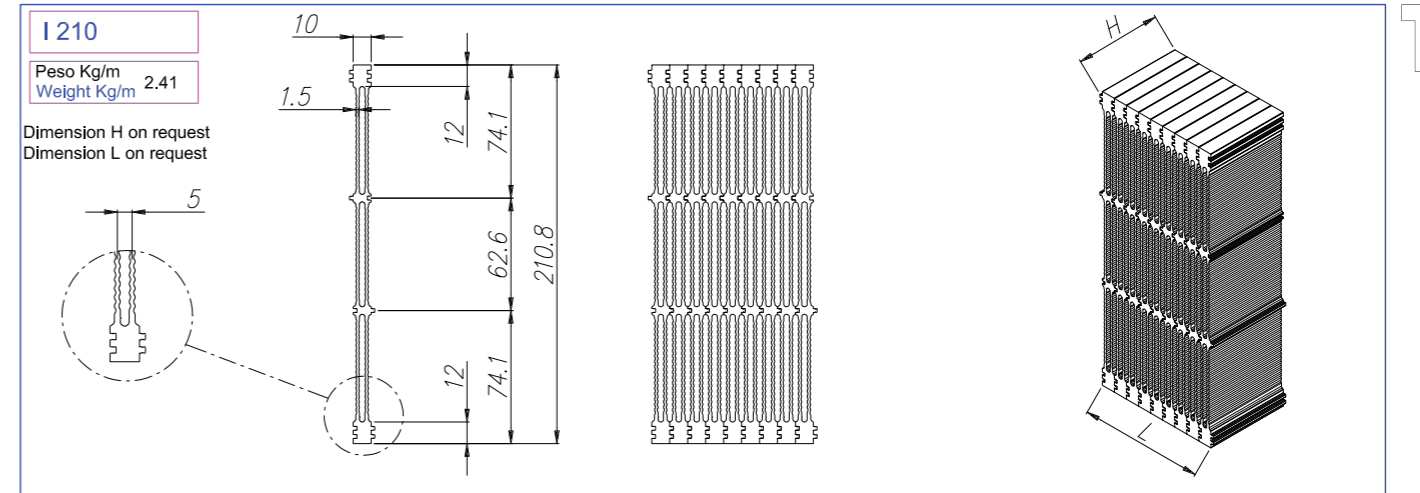

DATA SHEET		PART NUMBER		I 210x80/210		I	L	H		
						210	80	200		
PROVA TEST	CARICO PRINCIPALE MAIN POWER LOAD W	CARICO SECONDARIO MINOR POWER LOAD W	VENTOLA 1 FAN 1 TYPE	VENTOLA 2 FAN 2 TYPE	$\Delta T$ °C	RT °C/W	VELOCITA' USCITA ARIA OUTGOING AIR SPEED m/sec	D.D.P. mm H <sub>2</sub> O		
1	400	400	*	*	26.0	0.0325	7.5			
2	400		*	*	23.5	0.0587	7.5			
3	400		*	*	27.0	0.0675	5.0	5.0		
4	400	400	*	*	30.0	0.0375	5.0	5.0		

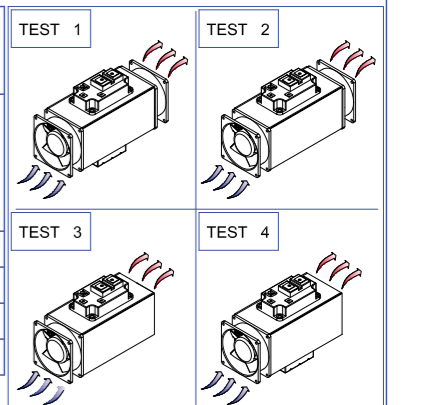

A

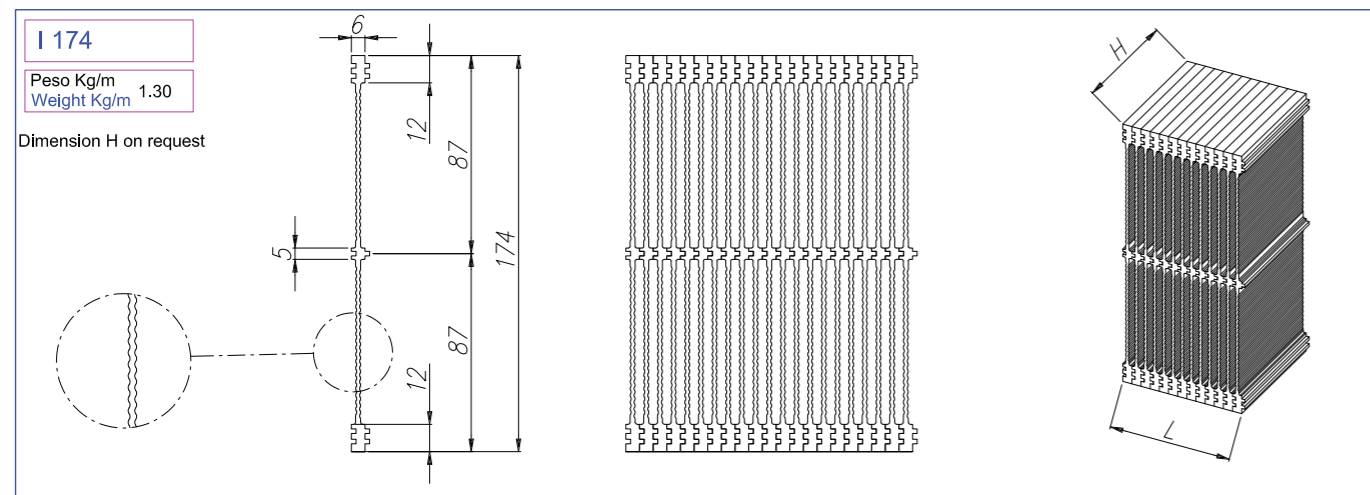

DATA SHEET		PART NUMBER		I 174x170/180		I	L	H		
						174	170	180		
PROVA TEST	CARICO PRINCIPALE MAIN POWER LOAD W	CARICO SECONDARIO MINOR POWER LOAD W	VENTOLA 1 FAN 1 TYPE	VENTOLA 2 FAN 2 TYPE	$\Delta T$ °C	RT °C/W	VELOCITA' USCITA ARIA OUTGOING AIR SPEED m/sec	D.D.P. mm H <sub>2</sub> O		
1	900	900	*	*	30.7	0.0170	5.5			
2	1225		*	*	35	0.0285	5.5			
3	1225		*	*	43.7	0.0356	3.5	3.0		
4	900	900	*	*	43.3	0.0240	3.5	3.0		

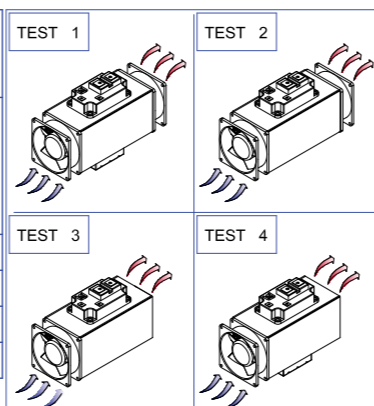

B

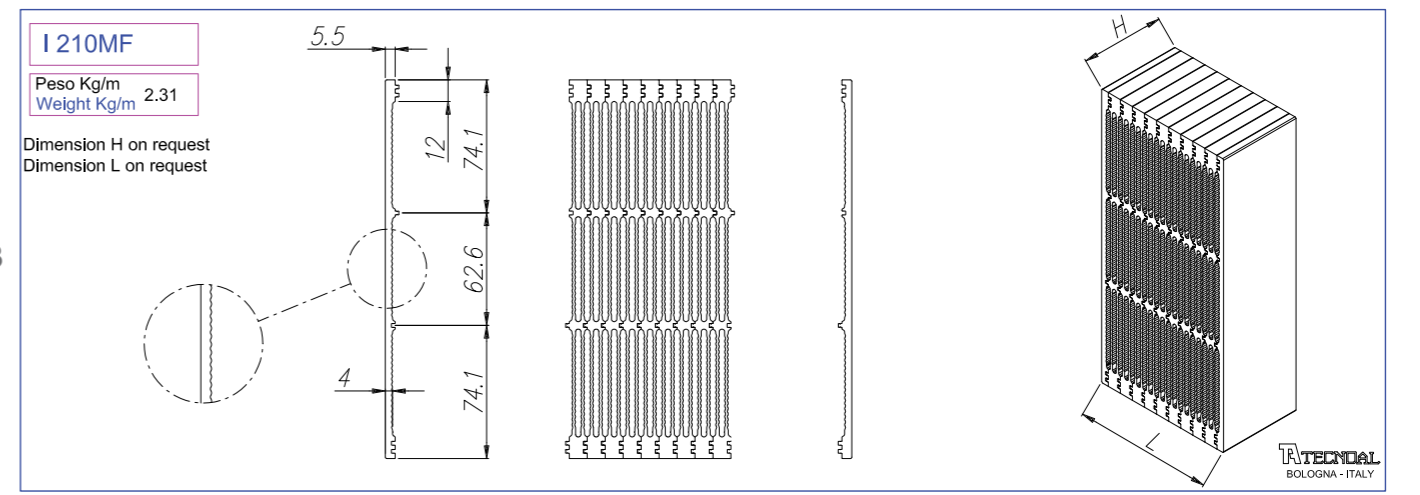

DATA SHEET		PART NUMBER		I 210MFx80/210		I	L	H		
						210	80	200		
PROVA TEST	CARICO PRINCIPALE MAIN POWER LOAD W	CARICO SECONDARIO MINOR POWER LOAD W	VENTOLA 1 FAN 1 TYPE	VENTOLA 2 FAN 2 TYPE	$\Delta T$ °C	RT °C/W	VELOCITA' USCITA ARIA OUTGOING AIR SPEED m/sec	D.D.P. mm H <sub>2</sub> O		
1	400	400	*	*	26.0	0.0325	7.5			
2	400		*	*	23.5	0.0587	7.5			
3	400		*	*	27.0	0.0675	5.0	5.0		
4	400	400	*	*	30.0	0.0375	5.0	5.0		



B



**I 125W1A**

Peso Kg/m 16.00  
Weight Kg/m

Ventilazione forzata  
Forced ventilation

Lung. campione mm  
Sample length mm  
300

Velocità dell'aria in uscita (m/sec)  
Outgoing air speed (m/sec)  
6

Rt °C/W 0.048

Dimension H on request

**I 125V2 (CODE OLD)**

**ATECNAL**  
BOLOGNA - ITALY

**I 125W4A**

Peso Kg/m 17.90  
Weight Kg/m

Ventilazione forzata  
Forced ventilation

Lung. campione mm  
Sample length mm  
300

Velocità dell'aria in uscita (m/sec)  
Outgoing air speed (m/sec)  
6

Rt °C/W 0.041

Dimension H on request

**I 125X (CODE OLD)**

**ATECNAL**  
BOLOGNA - ITALY

**I 125W2A**

Peso Kg/m 16.40  
Weight Kg/m

Ventilazione forzata  
Forced ventilation

Lung. campione mm  
Sample length mm  
300

Velocità dell'aria in uscita (m/sec)  
Outgoing air speed (m/sec)  
6

Rt °C/W 0.047

Dimension H on request

**I 125Y (CODE OLD)**

**ATECNAL**  
BOLOGNA - ITALY

**I 125W5A**

Peso Kg/m 19.20  
Weight Kg/m

Ventilazione forzata  
Forced ventilation

Lung. campione mm  
Sample length mm  
300

Velocità dell'aria in uscita (m/sec)  
Outgoing air speed (m/sec)  
6

Rt °C/W 0.039

Dimension H on request

**I 125R (CODE OLD)**

**ATECNAL**  
BOLOGNA - ITALY

**I 125W3A**

Peso Kg/m 16.70  
Weight Kg/m

Ventilazione forzata  
Forced ventilation

Lung. campione mm  
Sample length mm  
300

Velocità dell'aria in uscita (m/sec)  
Outgoing air speed (m/sec)  
6

Rt °C/W 0.045

Dimension H on request

**I 125H (CODE OLD)**

**ATECNAL**  
BOLOGNA - ITALY

**I 125W6A**

Peso Kg/m 25.60  
Weight Kg/m

Ventilazione forzata  
Forced ventilation

Lung. campione mm  
Sample length mm  
300

Velocità dell'aria in uscita (m/sec)  
Outgoing air speed (m/sec)  
6

Rt °C/W 0.029

Dimension H on request

**I 125W (CODE OLD)**

**ATECNAL**  
BOLOGNA - ITALY

**I 125W7A**

Peso Kg/m 31.70  
Weight Kg/m 31.70

Ventilazione forzata  
Forced ventilation

Lung. campione mm  
Sample length mm 300

Velocità dell'aria in uscita (m/sec)  
Outgoing air speed (m/sec) 6

Rt °C/W 0.024

Dimension H on request

Su richiesta foratura M3x8mm per fissaggio ventole 120x120  
On request holes M3x8mm for fans 120x120

**A**

**I 125W9A**

Peso Kg/m 47.80  
Weight Kg/m 47.80

Ventilazione forzata  
Forced ventilation

Lung. campione mm  
Sample length mm 300

Velocità dell'aria in uscita (m/sec)  
Outgoing air speed (m/sec) 6

Rt °C/W 0.016

Dimension H on request

Su richiesta foratura M3x8mm per fissaggio ventole 120x120  
On request holes M3x8mm for fans 120x120

**A**

**I 125W8A**

Peso Kg/m 38.10  
Weight Kg/m 38.10

Ventilazione forzata  
Forced ventilation

Lung. campione mm  
Sample length mm 300

Velocità dell'aria in uscita (m/sec)  
Outgoing air speed (m/sec) 6

Rt °C/W 0.0195

Dimension H on request

**I 125Z (CODE OLD)**

**B**

**I 125W10A**

Peso Kg/m 53.10  
Weight Kg/m 53.10

Ventilazione forzata  
Forced ventilation

Lung. campione mm  
Sample length mm 300

Velocità dell'aria in uscita (m/sec)  
Outgoing air speed (m/sec) 6

Rt °C/W 0.014

Dimension H on request

**I 125S (CODE OLD)**

**B**

<b>I 125W11A</b>	Peso Kg/m Weight Kg/m 63.85	Ventilazione forzata Forced ventilation	Lung. campione mm Sample length mm 300	Velocità dell'aria in uscita (m/sec) Outgoing air speed (m/sec) 6	Rt °C/W 0.012
<b>I 125T (CODE OLD)</b>					

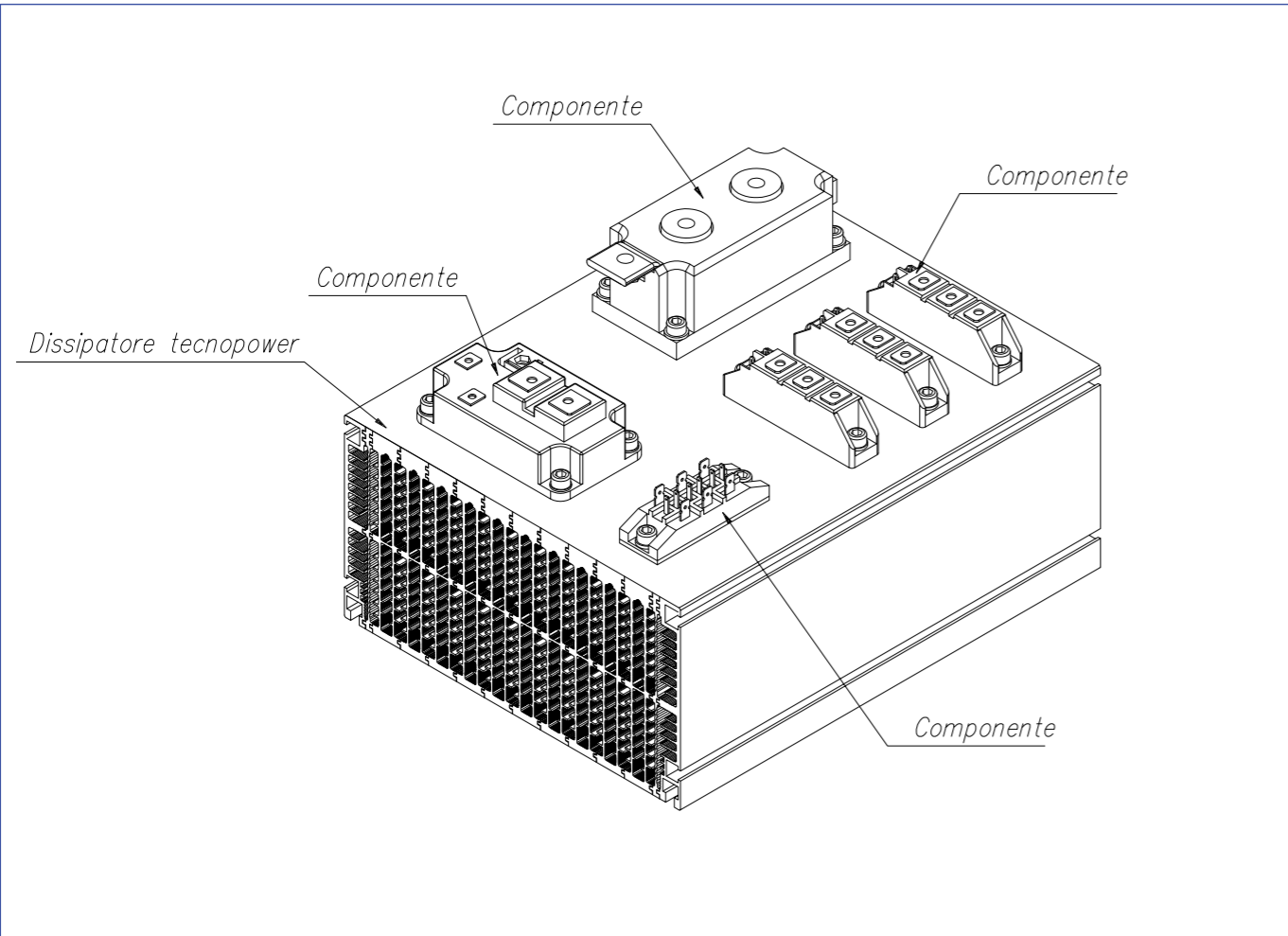
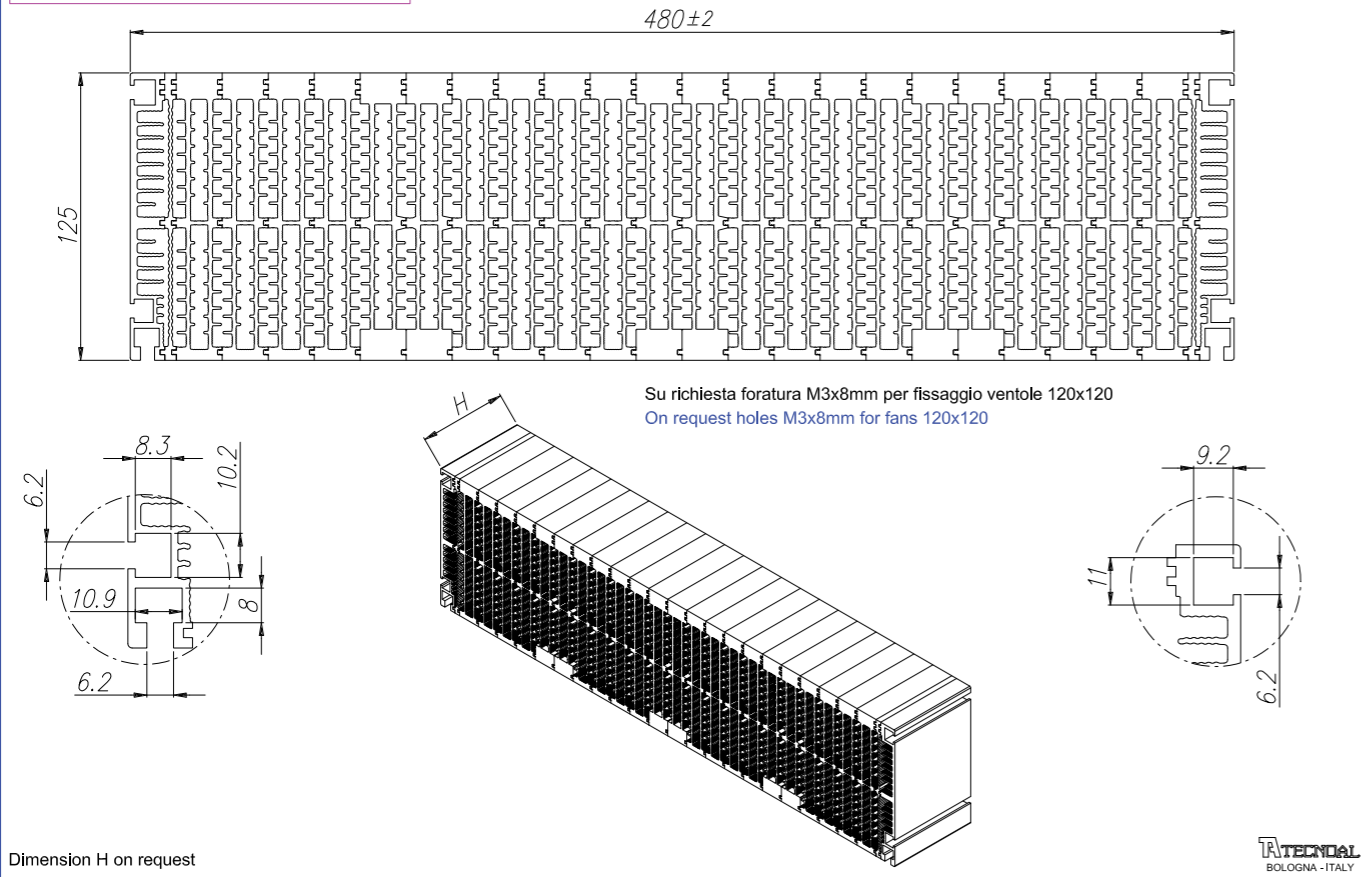

<b>I 125W1B</b>	Peso Kg/m Weight Kg/m 16.80	Ventilazione forzata Forced ventilation	Lung. campione mm Sample length mm 300	Velocità dell'aria in uscita (m/sec) Outgoing air speed (m/sec) 6.0	Rt °C/W 0.047
-----------------	--------------------------------	--	---	--	---------------

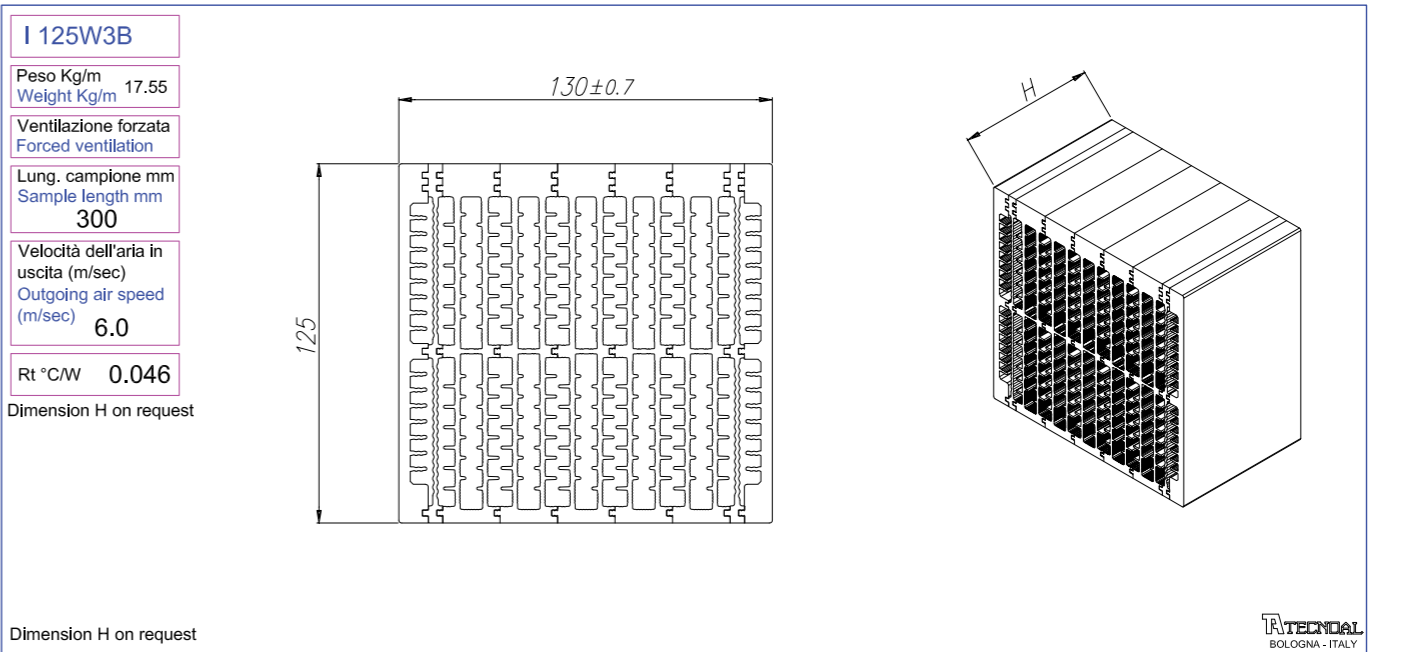
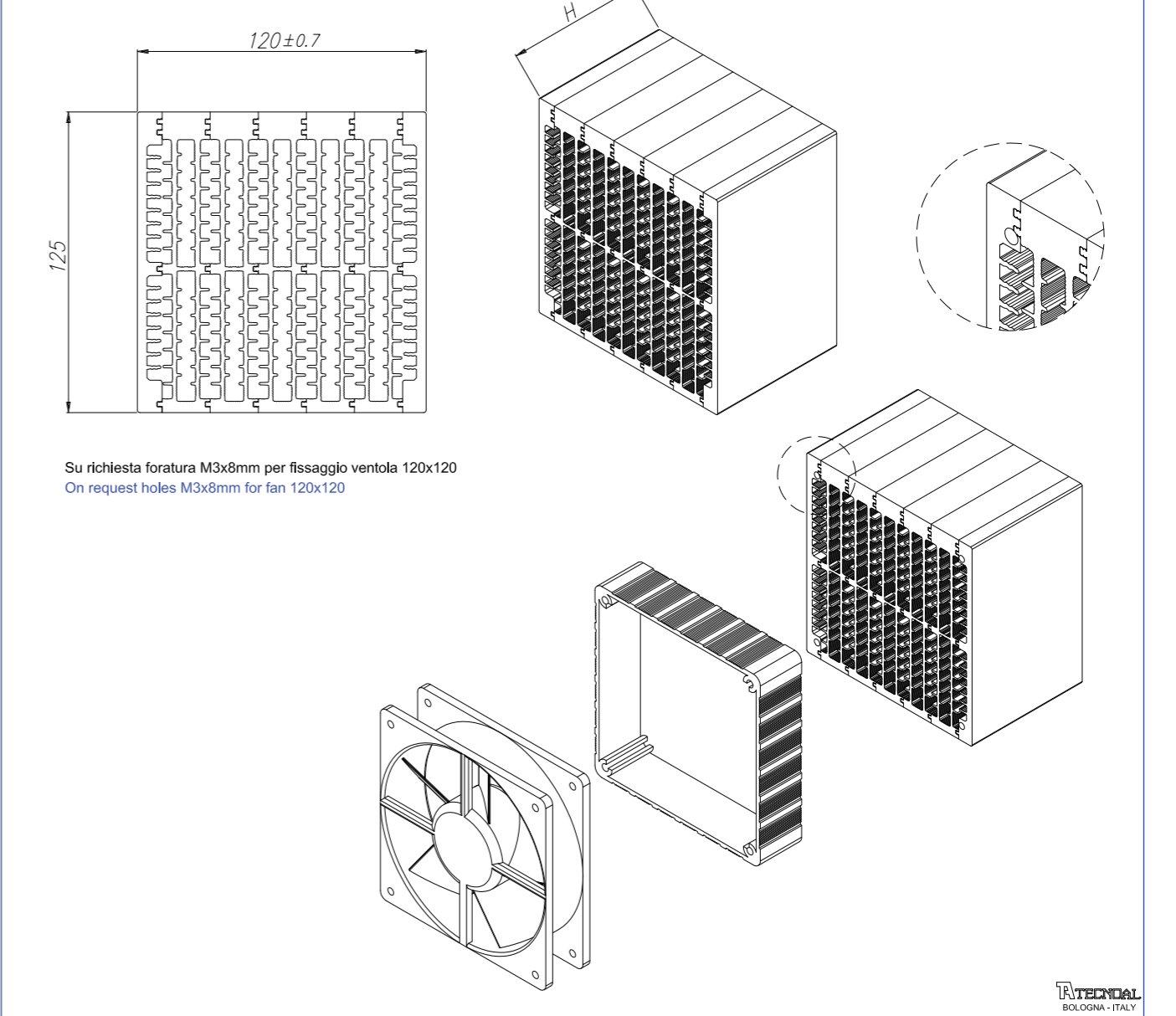

<b>I 125W3B</b>
Peso Kg/m Weight Kg/m 17.55
Ventilazione forzata Forced ventilation
Lung. campione mm Sample length mm 300
Velocità dell'aria in uscita (m/sec) Outgoing air speed (m/sec) 6.0
Rt °C/W 0.046
Dimension H on request

Dimension H on request

<b>I 125W3BA</b>
Peso Kg/m Weight Kg/m 18.30
Ventilazione forzata Forced ventilation
Lung. campione mm Sample length mm 300
Velocità dell'aria in uscita (m/sec) Outgoing air speed (m/sec) 6.0
Rt °C/W 0.044
Dimension H on request

Su richiesta foratura M3x8mm per fissaggio ventola 120x120  
On request holes M3x8mm for fan 120x120

TECNOAL BOLOGNA - ITALY

<b>I 125W4B</b>
Peso Kg/m Weight Kg/m 20.40
Ventilazione forzata Forced ventilation
Lung. campione mm Sample length mm 300
Velocità dell'aria in uscita (m/sec) Outgoing air speed (m/sec) 6.0
Rt °C/W 0.040
Dimension H on request

Su richiesta foratura M3x8mm per fissaggio ventola 120x120  
On request holes M3x8mm for fan 120x120

TECNOAL BOLOGNA - ITALY

<b>I 125W5B</b>
Peso Kg/m Weight Kg/m 20.80
Ventilazione forzata Forced ventilation
Lung. campione mm Sample length mm 300
Velocità dell'aria in uscita (m/sec) Outgoing air speed (m/sec) 6.0
Rt °C/W 0.038
Dimension H on request

TECNOAL BOLOGNA - ITALY

<b>I 125W5BA</b>	Peso Kg/m Weight Kg/m 21.90	Ventilazione forzata Forced ventilation	Lung. campione mm Sample length mm 300	Velocità dell'aria in uscita (m/sec) Outgoing air speed (m/sec) 6.0	Rt °C/W 0.039
------------------	--------------------------------	--	---	--	---------------

Su richiesta foratura M3x8mm per fissaggio ventola 120x120  
On request holes M3x8mm for fan 120x120

Dimension H on request

TECNOAL BOLOGNA - ITALY

<b>I 125W6B</b>	Peso Kg/m Weight Kg/m 26.90	Ventilazione forzata Forced ventilation	Lung. campione mm Sample length mm 300	Velocità dell'aria in uscita (m/sec) Outgoing air speed (m/sec) 6.0	Rt °C/W 0.028
-----------------	--------------------------------	--	---	--	---------------

Dimension H on request

TECNOAL BOLOGNA - ITALY

<b>I 125W7B</b>	Peso Kg/m Weight Kg/m 31.90	Ventilazione forzata Forced ventilation	Lung. campione mm Sample length mm 300	Velocità dell'aria in uscita (m/sec) Outgoing air speed (m/sec) 6.0	Rt °C/W 0.023
-----------------	--------------------------------	--	---	--	---------------

Dimension H on request

A

<b>I 125W9B</b>	Peso Kg/m Weight Kg/m 49.50	Ventilazione forzata Forced ventilation	Lung. campione mm Sample length mm 300	Velocità dell'aria in uscita (m/sec) Outgoing air speed (m/sec) 6.0	Rt °C/W 0.0153
-----------------	--------------------------------	--	---	--	----------------

Dimension H on request

A

<b>I 125W8B</b>	Peso Kg/m Weight Kg/m 39.40	Ventilazione forzata Forced ventilation	Lung. campione mm Sample length mm 300	Velocità dell'aria in uscita (m/sec) Outgoing air speed (m/sec) 6.0	Rt °C/W 0.0193
-----------------	--------------------------------	--	---	--	----------------

Dimension H on request

B

<b>I 125W10B</b>	Peso Kg/m Weight Kg/m 54.35	Ventilazione forzata Forced ventilation	Lung. campione mm Sample length mm 300	Velocità dell'aria in uscita (m/sec) Outgoing air speed (m/sec) 6.0	Rt °C/W 0.0135
------------------	--------------------------------	--	---	--	----------------

Dimension H on request

B

I 125W11B	Peso Kg/m Weight Kg/m 65.50	Ventilazione forzata Forced ventilation	Lung. campione mm Sample length mm 300	Velocità dell'aria in uscita (m/sec) Outgoing air speed (m/sec) 6.0	Rt °C/W 0.0115
-----------	--------------------------------	--	---	--	----------------

I 125TTC (CODE OLD)

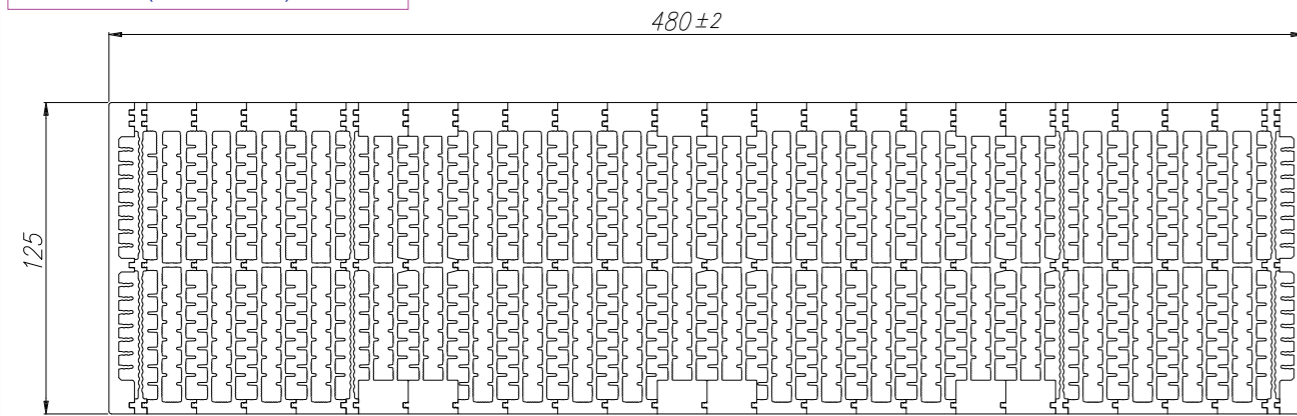

Su richiesta foratura M3x8mm per fissaggio ventole 120x120  
On request holes M3x8mm for fans 120x120

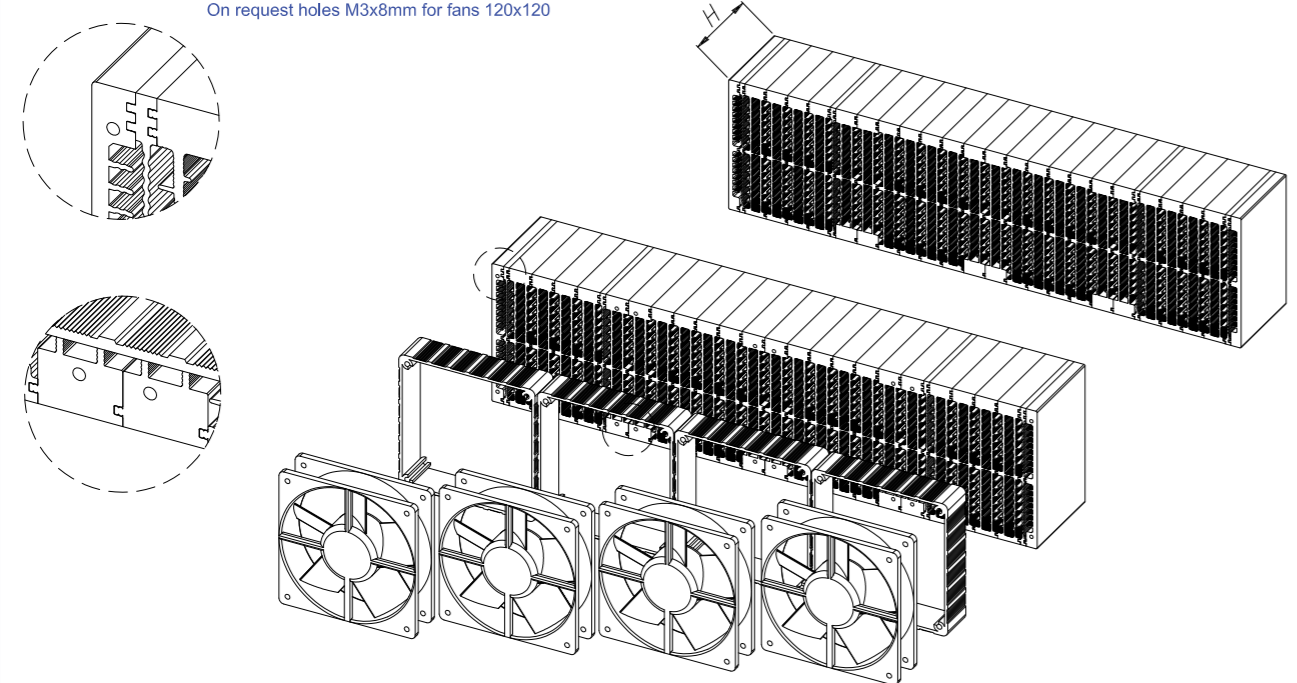

Dimension H on request

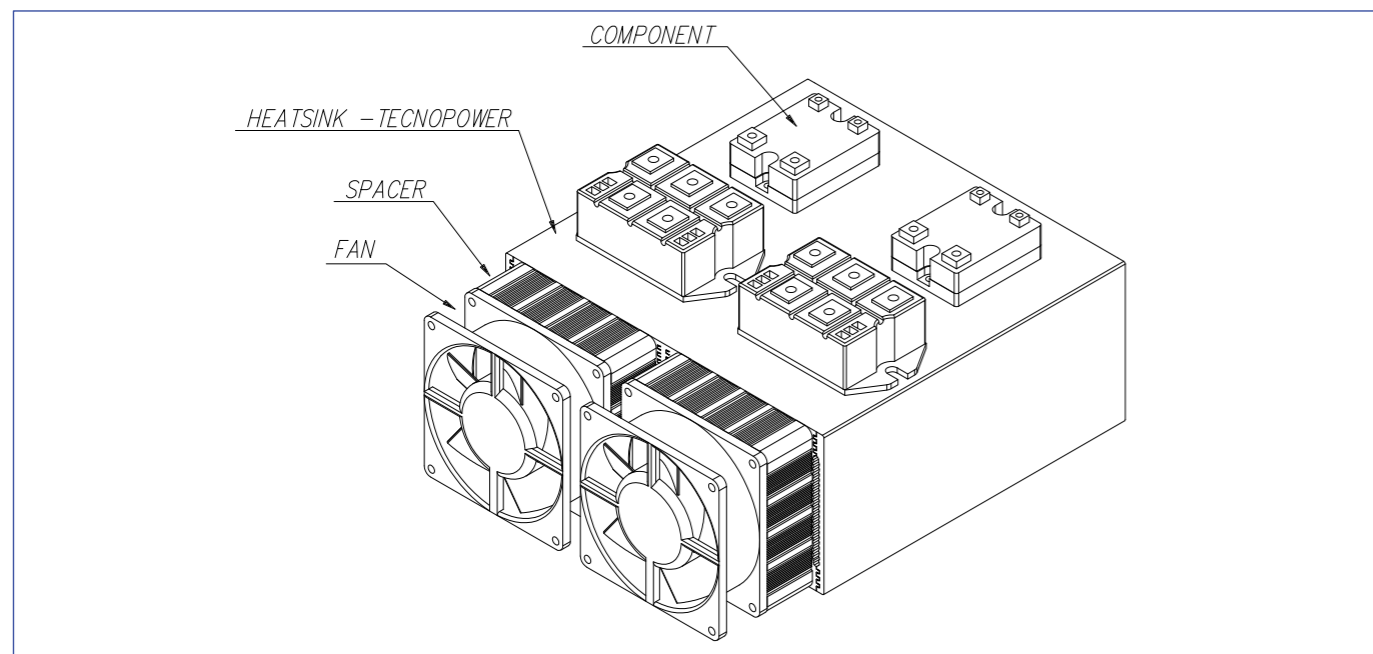

I 125W1C	Peso Kg/m Weight Kg/m 16.10	Ventilazione forzata Forced ventilation	Lung. campione mm Sample length mm 300	Velocità dell'aria in uscita (m/sec) Outgoing air speed (m/sec) 6.0	Rt °C/W 0.046
----------	--------------------------------	--	---	--	---------------

A

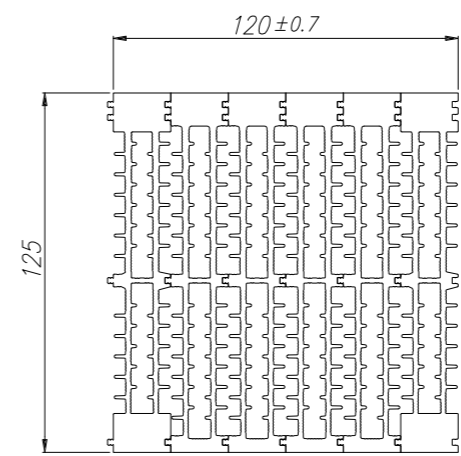

Su richiesta foratura M3x8mm per fissaggio ventola 120x120  
On request holes M3x8mm for fan 120x120

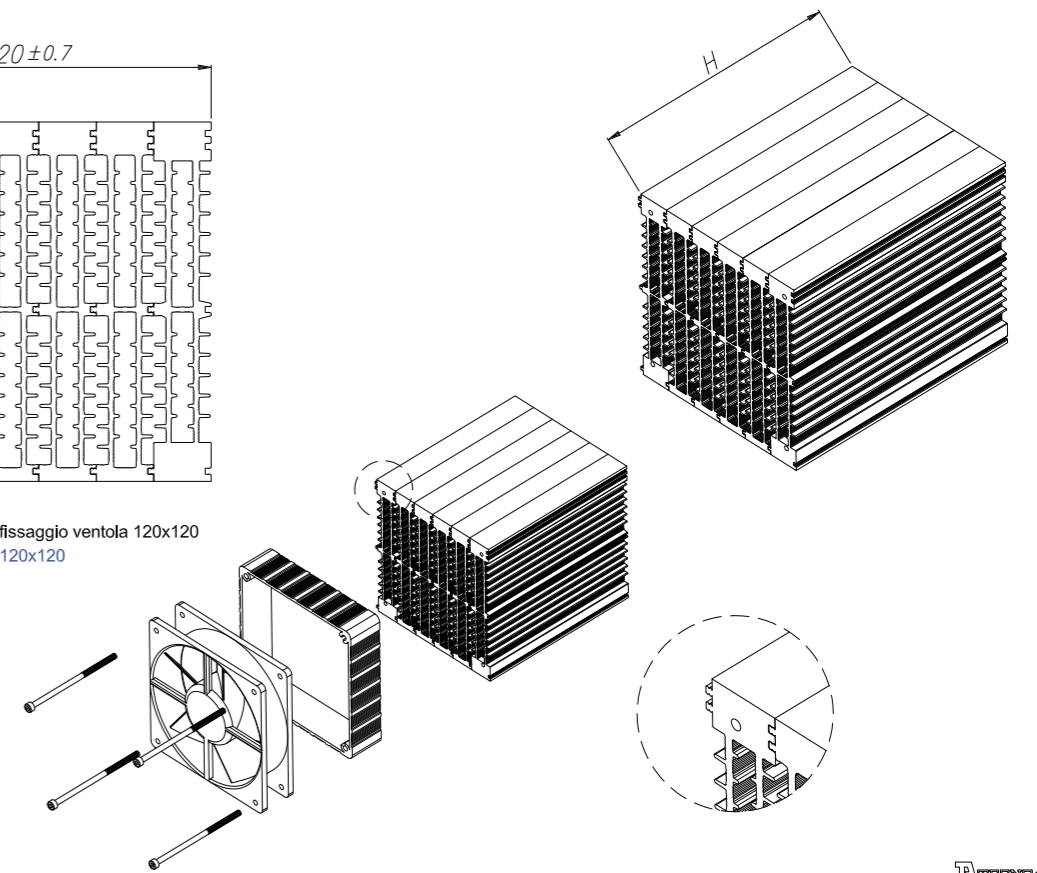

Dimension H on request



I 125W2C	Peso Kg/m Weight Kg/m 16.80	Ventilazione forzata Forced ventilation	Lung. campione mm Sample length mm 300	Velocità dell'aria in uscita (m/sec) Outgoing air speed (m/sec) 6.0	Rt °C/W 0.045
----------	--------------------------------	--	---	--	---------------

B

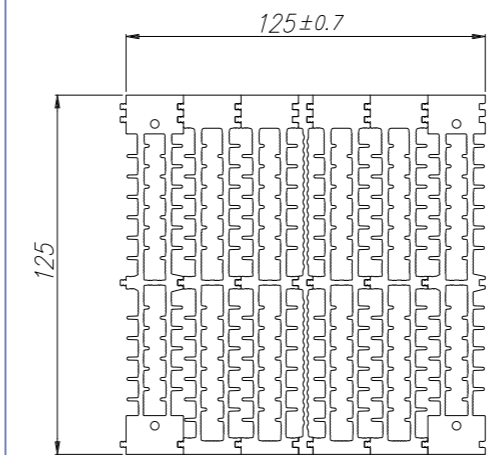

Su richiesta foratura M3x8mm per fissaggio ventola 120x120  
On request holes M3x8mm for fan 120x120

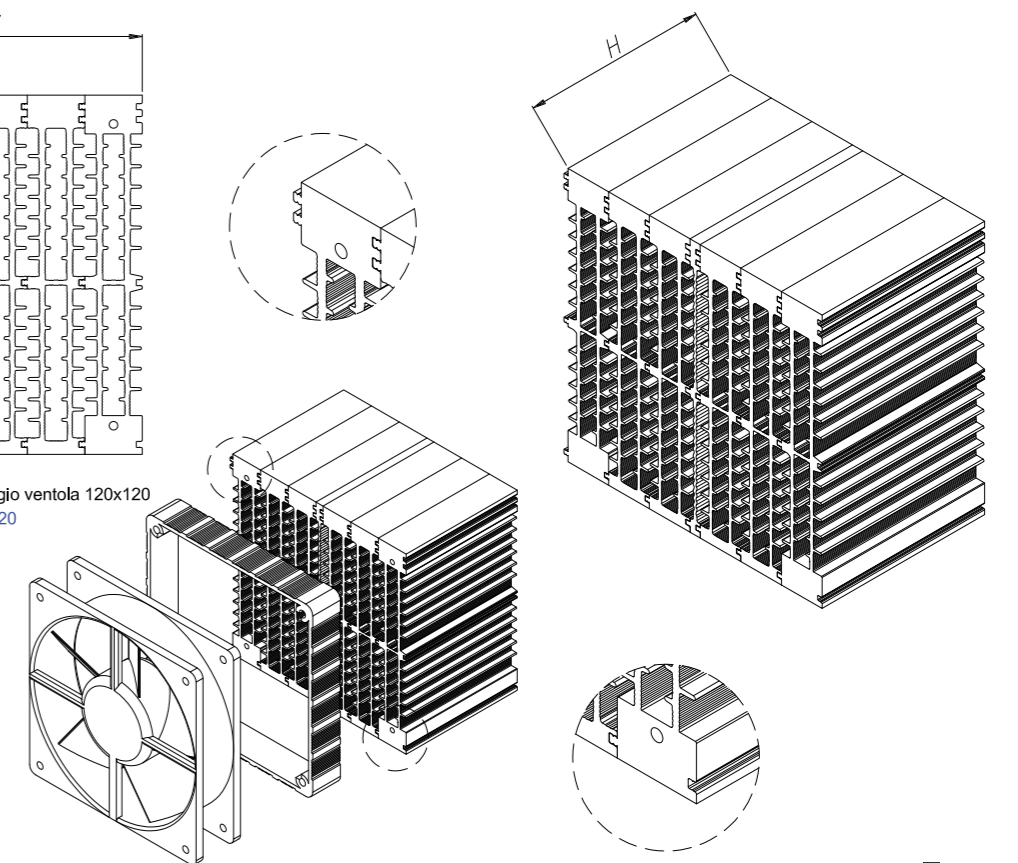

Dimension H on request



<b>I 125W3C</b>	Peso Kg/m Weight Kg/m 18.20	Ventilazione forzata Forced ventilation	Lung. campione mm Sample length mm 300	Velocità dell'aria in uscita (m/sec) Outgoing air speed (m/sec) 6.0	Rt °C/W 0.043
-----------------	--------------------------------	--	---	--	---------------

Su richiesta foratura M3x8mm per fissaggio ventola 120x120  
On request holes M3x8mm for fan 120x120

Dimension H on request

TECNOAL BOLOGNA - ITALY

<b>I 125W5C</b>	Peso Kg/m Weight Kg/m 20.10	Ventilazione forzata Forced ventilation	Lung. campione mm Sample length mm 300	Velocità dell'aria in uscita (m/sec) Outgoing air speed (m/sec) 6.0	Rt °C/W 0.037
-----------------	--------------------------------	--	---	--	---------------

Su richiesta foratura M3x8mm per fissaggio ventola 120x120  
On request holes M3x8mm for fan 120x120

Dimension H on request

TECNOAL BOLOGNA - ITALY

<b>I 125W4C</b>	Peso Kg/m Weight Kg/m 18.6	Ventilazione forzata Forced ventilation	Lung. campione mm Sample length mm 300	Velocità dell'aria in uscita (m/sec) Outgoing air speed (m/sec) 6.0	Rt °C/W 0.039
-----------------	-------------------------------	--	---	--	---------------

Su richiesta foratura M3x8mm per fissaggio ventola 120x120  
On request holes M3x8mm for fan 120x120

Dimension H on request

TECNOAL BOLOGNA - ITALY

<b>I 125W7C</b>	Peso Kg/m Weight Kg/m 32.20	Ventilazione forzata Forced ventilation	Lung. campione mm Sample length mm 300	Velocità dell'aria in uscita (m/sec) Outgoing air speed (m/sec) 6.0	Rt °C/W 0.022
-----------------	--------------------------------	--	---	--	---------------

Su richiesta foratura M3x8mm per fissaggio ventole 120x120  
On request holes M3x8mm for fans 120x120

Dimension H on request

TECNOAL BOLOGNA - ITALY

<b>I 125W9C</b>	Peso Kg/m Weight Kg/m 48.25	Ventilazione forzata Forced ventilation	Lung. campione mm Sample length mm 300	Velocità dell'aria in uscita (m/sec) Outgoing air speed (m/sec) 6.0	Rt °C/W 0.0152
-----------------	--------------------------------	--	---	--	----------------

360±1.5

125

Dimension H on request

Su richiesta foratura M3x8mm per fissaggio ventole 120x120  
On request holes M3x8mm for fans 120x120

TECNOAL BOLOGNA - ITALY

<b>I 125W11C</b>	Peso Kg/m Weight Kg/m 70.4	Ventilazione forzata Forced ventilation	Lung. campione mm Sample length mm 300	Velocità dell'aria in uscita (m/sec) Outgoing air speed (m/sec) 6.0	Rt °C/W 0.0116
------------------	-------------------------------	--	---	--	----------------

480±2

125

Dimension H on request

Su richiesta foratura M3x8mm per fissaggio ventole 120x120  
On request holes M3x8mm for fans 120x120

TECNOAL BOLOGNA - ITALY

A

B

<b>I 140A</b> Kg/m 0,30	<b>I 140M</b> Kg/m 0,25	<b>I 140F</b> Kg/m 0,21	<b>I 140B</b> Kg/m 0,54
<b>I 150</b> Kg/m 0,41	<b>I 150MF</b> Kg/m 0,47	<b>I 154A</b> Kg/m 0,35	
<b>I 154D</b> Kg/m 0,55	<b>I 155</b> Kg/m 0,34	<b>I 156</b> Kg/m 0,36	
<b>I 157</b> Kg/m 0,40	<b>I 157E</b> Kg/m 0,39	<b>I 162A</b> Kg/m 0,47	
<b>I 162B</b> Kg/m 0,40	<b>I 162M</b> Kg/m 0,76	<b>I 162F</b> Kg/m 0,70	<b>I 162D</b> Kg/m 0,85
<b>I 164</b> Kg/m 0,38	<b>I 166</b> Kg/m 0,69	<b>I 171</b> Kg/m 1,30	
<b>I 171MF</b> Kg/m 0,45	<b>I 171T</b> Kg/m 0,80	<b>I 175</b> Kg/m 0,51	



 I 75A Kg/m 0,56	 I 75AB Kg/m 0,56	 I 75M Kg/m 0,45	 I 75F Kg/m 0,47
 I 76D Kg/m 0,85	 I 76E Kg/m 0,50	 I 76EF Kg/m 0,72	 I 76EM Kg/m 0,81
 I 77 Kg/m 0,50	 I 80 Kg/m 0,53	 I 80A Kg/m 0,68	
 I 80MF Kg/m 0,65	 I 81 Kg/m 0,65	 I 84 Kg/m 0,54	
 I 84B Kg/m 0,48	 I 84C Kg/m 1,11	 I 84D Kg/m 0,48	
 I 84G Kg/m 1,07	 I 84M Kg/m 0,51	 I 84F Kg/m 0,53	 I 84MA Kg/m 0,58
 I 85B Kg/m 0,58	 I 86E Kg/m 0,58	 I 86ED Kg/m 1,15	
		 I 84FA Kg/m 0,58	

 I 90 Kg/m 0,61	 I 90M Kg/m 0,57	 I 90F Kg/m 0,44	 I 91 Kg/m 0,68
 I 91A Kg/m 0,55	 I 91MF Kg/m 0,94	 I 93 Kg/m 0,55	
 I 98T Kg/m 0,75	 I 100A Kg/m 0,54	 I 100CA Kg/m 1,13	
 I 105 Kg/m 0,65	 I 105A Kg/m 0,80	 I 105B Kg/m 0,56	
 I 105C Kg/m 1,20	 I 105M Kg/m 1,38	 I 105F Kg/m 1,00	 I 117C Kg/m 1,50
 I 117CA Kg/m 1,55	 I 117F Kg/m 1,10	 I 117M Kg/m 1,14	 I 117FA Kg/m 1,45
 I 117MA Kg/m 1,53	 I 1117MB Kg/m 0,98	 I 125 Kg/m 1,75	 I 125A Kg/m 0,73

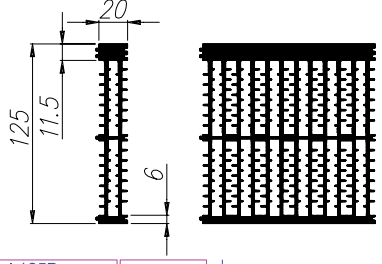
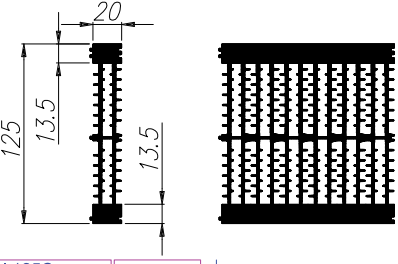
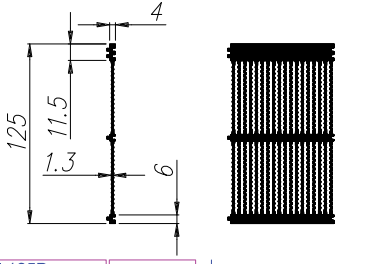
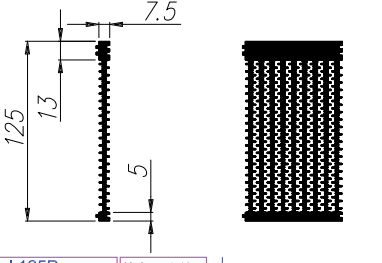
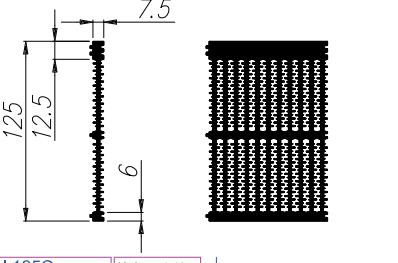
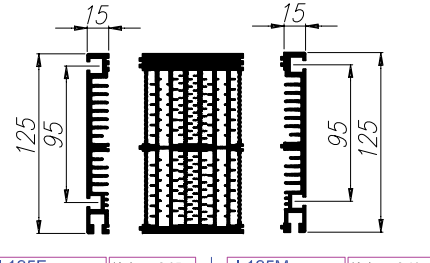
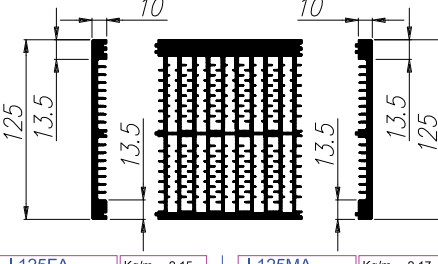
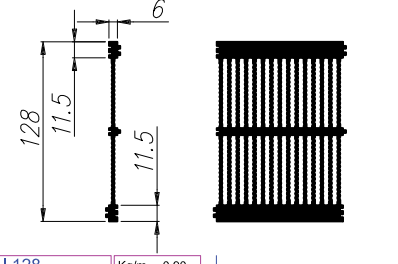
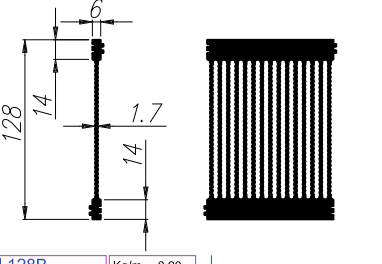
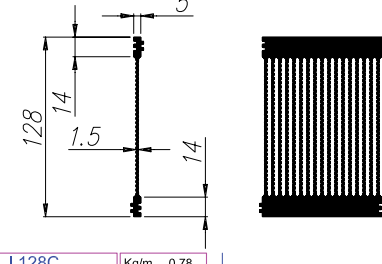
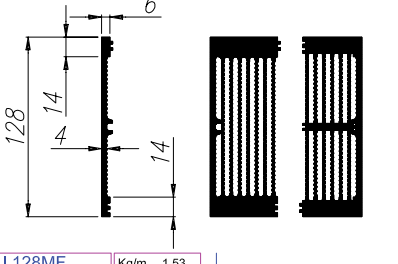
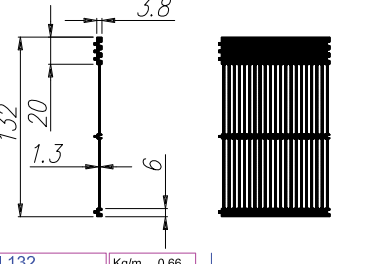
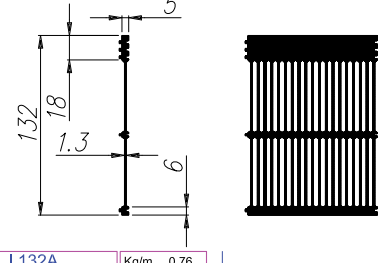
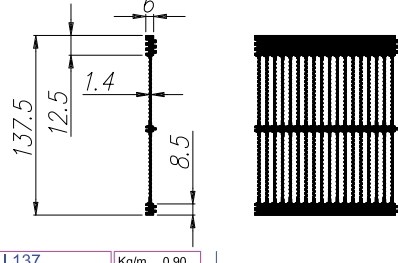
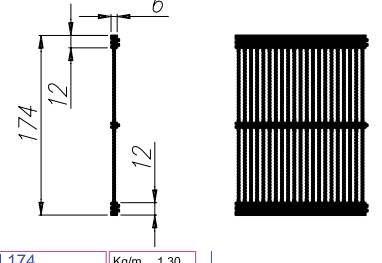
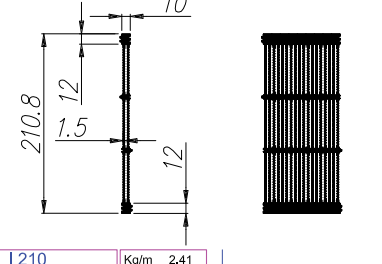
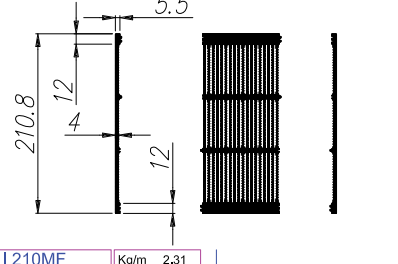

 <p>I 125B Kg/m 2.50</p>	 <p>I 125C Kg/m 3.04</p>	 <p>I 125D Kg/m 0.61</p>
 <p>I 125P Kg/m 1.40</p>	 <p>I 125Q Kg/m 1.40</p>	 <p>I 125F Kg/m 2.05 I 125M Kg/m 2.10</p>
 <p>I 125FA Kg/m 2.15 I 125MA Kg/m 2.17</p>	 <p>I 128 Kg/m 0.90</p>	 <p>I 128B Kg/m 0.90</p>
 <p>I 128C Kg/m 0.78</p>	 <p>I 128MF Kg/m 1.53</p>	 <p>I 132 Kg/m 0.66</p>
 <p>I 132A Kg/m 0.76</p>	 <p>I 137 Kg/m 0.90</p>	 <p>I 174 Kg/m 1.30</p>
 <p>I 210 Kg/m 2.41</p>	 <p>I 210MF Kg/m 2.31</p>	