

Overview

KEMET's PEH169 Series is a long-life electrolytic capacitor with outstanding reliability and electrical performance. The device has a polarized all-welded design, heavy duty screw terminals, extended cathode construction, safety vent, and plastic insulation. The PEH169 Series winding is housed in a cylindrical aluminum can with a reinforced molded lid incorporating a safety vent. The sealing system is designed for electrolyte leakage-free operation and a very low gas-diffusion rate of electrolyte. Mechanical contact between the winding and case allows excellent heat transfer from the winding to the ambient, which means cooler operation. Low ESR is the result of a low resistive paper/electrolyte system, at least two tabs per foil and all-welded design.

Applications

Typical applications for KEMET's PEH169 capacitor include smoothing, energy storage or pulse operation in telecommunication demanding power supplies, process control, AC motor control, traction, welding, and measuring.

Benefits

- High performance
- Long life, up to 18,000 hours at +105°C (V_R , I_R applied)
- Low ESR and ESL
- High stability, 10 years shelf life
- Optimized designs available on request



Part Number System

PEH169	E		A	468	0	Q	U2
Series	Rated Voltage (VDC)		Size Code	Capacitance Code (µF)	Version	Capacitance Tolerance	Stud Option
Screw Terminal Aluminum Electrolytic	E = 10 G = 16 H = 25 K = 40 M = 63	P = 100 Q = 160 R = 200 S = 250 U = 350	See Dimension Table	The second 2 digits indicate the 2 most significant digits of the capacitance value. The first digit indicates the total number digits.	0 = Standard	Q = -10 +30%	U2 = Plain Can B2 = Threaded mounting stud

Performance Characteristics

Item	Performance Characteristics		
Capacitance Range	100 – 330,000 μ F		
Rated Voltage	10 – 350 VDC		
Operating Temperature	-40 to +105°C		
Capacitance Tolerance	-10/+30% at 100 Hz / +20°C		
Operational Lifetime	D (mm)	Rated Voltage and Ripple Current at +105°C (hours)	Rated Voltage at +105°C (hours)
	35	7,000	
	50	8,000	
	65	10,000	
	75	13,000	
	90	18,000	25,000
Shelf Life	5,000 hours at +105°C or 10 years at +40°C 0 VDC		
Leakage Current	$I = 0.003 CV + 4,000$ (μ A)		
	C = rated capacitance (μ F), V = rated voltage (VDC). Voltage applied for 5 minutes at +20°C.		
Vibration Test Specifications		Procedure	Requirements
	D \leq 50 mm	0.75 mm displacement amplitude or 10 g maximum acceleration. Vibration applied for three 2-hour sessions at 10 – 500 Hz (Capacitor clamped by body).	No leakage of electrolyte or other visible damage. Deviations in capacitance and $\tan\delta$ from initial measurements must not exceed: $\Delta C/C < 5\%$
	D > 50 mm	0.75 mm displacement amplitude or 10 g maximum acceleration. Vibration applied for three 2-hour sessions at 10 – 55 Hz (Capacitor clamped by body).	
Standards	IEC 60384–4 long life grade 40/105/56, DIN 41240 type 1A CECC 30300, DIN 40040 GPF, DIN 41248		
CECC	CECC 30301-058, corresponding to CECC 30301-803		

Test Method & Performance

Endurance Life Test		
Conditions	Performance	
Temperature	+105°C	
Test Duration	2,000 hours	
Ripple Current	Maximum ripple current specified in table	
Voltage	The sum of DC voltage and the peak AC voltage must not exceed the rated voltage of the capacitor	
Performance	The following specifications will be satisfied when the capacitor is tested at +20°C:	
Capacitance Change	≤ 160 V	Within 15% of the initial value
	> 160 V	Within 10% of the initial value
Equivalent Series Resistance	Does not exceed 200% of the initial value	
Leakage Current	Does not exceed leakage current limit	

Dimensions – Millimeters

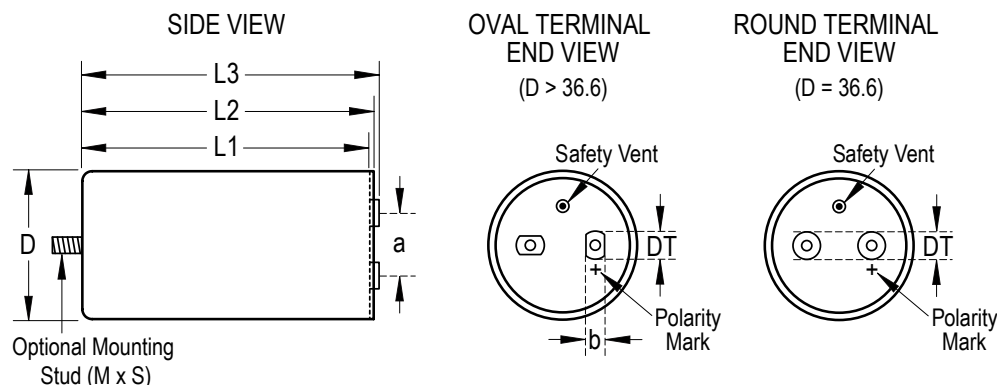

Reference Size (mm)	Size Code	Dimensions in mm					Mounting Stud (M x S)	Approximate Weight Grams
		D	L1	L2	L3	a		
35 x 51	A	36.6	51.5	54.5	58.9	13.0	M8 x 12	70
35 x 60	B	36.6	59.5	62.5	66.9	13.0	M8 x 12	85
35 x 75	C	36.6	73.5	76.5	80.9	13.0	M8 x 12	105
35 x 95	D	36.6	94.5	97.5	101.9	13.0	M8 x 12	130
50 x 75	H	51.6	74.5	77.5	82.4	22.0	M12 x 16	180
50 x 95	J	51.6	95.5	98.5	103.4	22.0	M12 x 16	240
50 x 105	K	51.6	103.5	106.5	111.4	22.0	M12 x 16	265
50 x 115	I*	51.6	115.5	118.5	123.4	22.0	M12 x 16	300
65 x 105	O	66.6	106.0	109.2	113.0	28.5	M12 x 16	415
65 x 115	Q*	66.6	118.0	121.2	125.0	28.5	M12 x 16	460.0
65 x 130	S*	66.6	129.0	132.2	136.0	28.5	M12 x 16	520.0
75 x 78	L	76.6	77.0	80.2	84.0	32.0	M12 x 16	430.0
75 x 98	P*	76.6	98.0	101.2	105.0	32.0	M12 x 16	530
75 x 105	T	76.6	106.0	109.2	113.0	32.0	M12 x 16	585
75 x 115	U	76.6	118.0	121.2	125.0	32.0	M12 x 16	640
75 x 145	V	76.6	146.0	149.2	153.0	32.0	M12 x 16	800
75 x 220	X	76.6	221.0	224.2	228.0	32.0	M12 x 16	1400
90 x 145	Y	91.6	145.5	148.7	152.4	32.0	M12 x 16	1400

Note: Dimensions include sleeving
Additional case sizes available on request

Termination Table

Reference Diameter	Thread	Termination Style	Dimensions in mm	
			DT	b
35	M5	Round	8	
50	M5	Oval	15	13
65	M5	Oval	15	13
75	M5	Oval	15	13
90	M5	Oval	15	13

Note: M6 and other termination options available on request

Shelf Life

The capacitance, ESR and impedance of a capacitor will not change significantly after extended storage periods, however the leakage current will very slowly increase. KEMET products are particularly stable and allow a shelf life in excess of three years at 40°C. See sectional specification under each product series for specific data.

Re-age (Reforming) Procedure

Apply the rated voltage to the capacitor at room temperature for a period of one hour, or until the leakage current has fallen to a steady value below the specified limit. During re-aging a maximum charging current of twice the specified leakage current or 5 mA (whichever is greater) is suggested.

Reliability

The reliability of a component can be defined as the probability that it will perform satisfactorily under a given set of conditions for a given length of time.

In practice, it is impossible to predict with absolute certainty how any individual component will perform; thus, we must utilize probability theory. It is also necessary to clearly define the level of stress involved (e.g. operating voltage, ripple current, temperature and time). Finally, the meaning of satisfactory performance must be defined by specifying a set of conditions which determine the end of life of the component.

Reliability as a function of time, $R(t)$, is normally expressed as: $R(t)=e^{-\lambda t}$
where $R(t)$ is the probability that the component will perform satisfactorily for time t , and λ is the failure rate.

Failure Rate

The failure rate is the number of components failing per unit time. The failure rate of most electronic components follows the characteristic pattern:

- Early failures are removed during the manufacturing process.
- The operational life is characterized by a constant failure rate.
- The wear out period is characterized by a rapidly increasing failure rate.

The failures in time (FIT) are given with a 60% confidence level for the various type codes. By convention, FIT is expressed as 1×10^{-9} failures per hour. Failure rate is also expressed as a percentage of failures per 1,000 hours.

e.g., 100 FIT = 1×10^{-7} failures per hour = 0.01%/1,000 hours

End of Life Definition

Catastrophic Failure: short circuit, open circuit or safety vent operation

Parametric Failure:

- Change in capacitance $> \pm 10\%$
- Leakage current $>$ specified limit
- ESR $> 2 \times$ initial ESR value

MTBF

The mean time between failures (MTBF) is simply the inverse of the failure rate.

$$MTBF = 1/\lambda$$

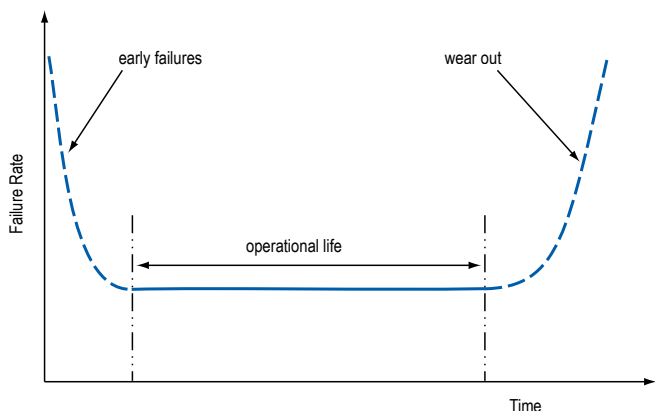

The failure rate is derived from our periodic test results. The failure rate (λ_p) is, therefore, only given at test temperature for life tests. An estimation is also given at 60°C.

The expected failure rate for this capacitor range is based on our periodic test results for capacitors with structural similarity.

T_a	Failure Rate per Hour
60°C	100 FIT

Failure rate per hour includes both catastrophic and parametric failures.

Environmental Compliance

As an environmentally conscious company, KEMET is working continuously with improvements concerning the environmental effects of both our capacitors and their production. In Europe (RoHS Directive) and in some other geographical areas like China, legislation has been put in place to prevent the use of some hazardous materials, such as lead (Pb), in electronic equipment. All products in this catalog are produced to help our customers' obligations to guarantee their products and fulfill these legislative requirements. The only material of concern in our products has been lead (Pb), which has been removed from all designs to fulfill the requirement of containing less than 0.1% of lead in any homogeneous material. KEMET will closely follow any changes in legislation world wide and makes any necessary changes in its products, whenever needed.

Some customer segments such as medical, military and automotive electronics may still require the use of lead in electrode coatings. To clarify the situation and distinguish products from each other, a special symbol is used on the packaging labels for RoHS compatible capacitors.

Because of customer requirements, there may appear additional markings such as LF = Lead Free or LFW = Lead Free Wires on the label.

Table 1 – Ratings & Part Number Reference

VDC	Rated Capacitance 100 Hz 20°C (µF)	Size Code	Reference Size D x L (mm)	Ripple Current Maximum			ESR Maximum		L _{ESL} Approximate (nH)	Part Number
				100 Hz 105°C (A)	10 kHz 50°C (A) ²	10 kHz 40°C (A)	100 Hz 20°C (mΩ)	100 kHz 20°C (mΩ)		
10	6800	A	35 x 51	5.2	21.8	15.4	46	37	12	PEH169EA4680Q(1)
10	10000	A	35 x 51	6.2	26.3	17.5	33	27	12	PEH169EA5100Q(1)
10	15000	B	35 x 60	7.4	28.9	20.5	23	19	12	PEH169EB5150Q(1)
10	22000	C	35 x 75	8.8	34.8	24.3	17	14	12	PEH169EC5220Q(1)
10	33000	D	35 x 95	10.4	38.3	28.0	12	10	12	PEH169ED5330Q(1)
10	47000	H	50 x 75	11.0	42.9	30.0	12	10	16	PEH169EH5470Q(1)
10	68000	J	50 x 95	13.5	51.8	34.1	9	8	16	PEH169EJ5680Q(1)
10	100000	K	50 x 105	14.0	48.5	35.0	8	7	16	PEH169EK6100Q(1)
10	150000	O	65 x 105	14.7	47.6	35.5	9	8	16	PEH169EO6150Q(1)
10	220000	T	75 x 105	19.4	62.8	46.7	6	5	17	PEH169ET6220Q(1)
10	330000	V	75 x 145	22.5	70.7	54.6	4	4	17	PEH169EV6330Q(1)
16	6800	A	35 x 51	5.5	25.5	16.7	36	28	12	PEH169GA4680Q(1)
16	10000	A	35 x 51	6.4	28.0	18.9	27	21	12	PEH169GA5100Q(1)
16	15000	C	35 x 75	8.3	34.3	24.6	18	14	12	PEH169GC5150Q(1)
16	22000	D	35 x 95	9.7	38.6	28.5	13	10	12	PEH169GD5220Q(1)
16	33000	H	50 x 75	11.7	43.0	31.0	12	10	16	PEH169GH5330Q(1)
16	47000	J	50 x 95	13.2	46.2	34.5	9	8	16	PEH169GJ5470Q(1)
16	68000	O	65 x 105	14.4	47.7	36.2	9	8	16	PEH169GO5680Q(1)
16	100000	T	75 x 105	21.6	70.9	54.7	6	5	17	PEH169GT6100Q(1)
16	150000	U	75 x 115	19.8	67.3	50.0	5	5	17	PEH169GU6150Q(1)
16	220000	V	75 x 145	23.6	74.7	58.0	4	4	17	PEH169GV6220Q(1)
25	4700	A	35 x 51	4.9	24.1	16.5	41	29	12	PEH169HA4470Q(1)
25	6800	A	35 x 51	5.8	27.7	18.5	30	22	12	PEH169HA4680Q(1)
25	10000	C	35 x 75	7.1	31.2	22.8	20	15	12	PEH169HC5100Q(1)
25	15000	D	35 x 95	8.7	36.8	27.2	15	11	12	PEH169HD5150Q(1)
25	22000	H	50 x 75	11.0	42.9	30.9	13	10	16	PEH169HH5220Q(1)
25	33000	J	50 x 95	12.6	46.5	34.6	10	8	16	PEH169HJ5330Q(1)
25	47000	O	65 x 105	15.8	53.7	42.1	8	7	16	PEH169HO5470Q(1)
25	68000	T	75 x 105	20.2	68.1	51.9	6	6	17	PEH169HT5680Q(1)
25	100000	U	75 x 115	21.9	70.3	55.4	5	5	17	PEH169HU6100Q(1)
25	150000	V	75 x 145	22.1	71.4	55.3	4	4	17	PEH169HV6150Q(1)
40	3300	A	35 x 51	4.6	26.3	17.6	41	25	12	PEH169KA4330Q(1)
40	4700	B	35 x 60	5.6	29.6	20.5	30	19	12	PEH169KB4470Q(1)
40	6800	C	35 x 75	6.7	32.6	23.6	22	14	12	PEH169KC4680Q(1)
40	10000	D	35 x 95	7.8	34.8	26.8	16	11	12	PEH169KD5100Q(1)
40	15000	H	50 x 75	10.2	42.9	30.5	14	10	16	PEH169KH5150Q(1)
40	22000	J	50 x 95	11.9	46.5	34.8	10	8	16	PEH169KJ5220Q(1)
40	33000	O	65 x 105	15.0	53.8	41.4	8	7	16	PEH169KO5330Q(1)
40	47000	T	75 x 105	19.9	69.5	55.0	6	5	17	PEH169KT5470Q(1)
40	68000	U	75 x 115	20.6	70.7	53.9	6	5	17	PEH169KU5680Q(1)
40	100000	V	75 x 145	23.0	71.0	59.0	4	4	17	PEH169KV6100Q(1)
63	1500	A	35 x 51	3.5	23.1	15.9	63	31	12	PEH169MA4150Q(1)
63	2200	A	35 x 51	4.1	27.0	18.1	46	23	12	PEH169MA4220Q(1)
63	3300	C	35 x 75	5.3	31.6	22.9	30	15	12	PEH169MC4330Q(1)
63	4700	D	35 x 95	6.2	34.2	25.9	22	11	12	PEH169MD4470Q(1)
63	6800	H	50 x 75	8.5	42.6	30.8	18	10	16	PEH169MH4680Q(1)
63	10000	J	50 x 95	9.9	45.3	34.2	13	8	16	PEH169MJ5100Q(1)
63	15000	O	65 x 105	13.1	53.0	41.1	10	6	16	PEH169MO5150Q(1)
63	22000	T	75 x 105	17.7	73.0	55.8	6	4	17	PEH169MT5220Q(1)
63	33000	U	75 x 115	18.9	71.0	54.3	6	5	17	PEH169MU5330Q(1)
63	47000	V	75 x 145	20.9	73.0	58.0	5	4	17	PEH169MV5470Q(1)
100	680	A	35 x 51	2.4	14.4	9.9	160	95	12	PEH169PA3680Q(1)
100	1000	A	35 x 51	2.9	17.4	11.7	110	67	12	PEH169PA4100Q(1)
100	1500	C	35 x 75	3.6	20.5	14.9	73	44	12	PEH169PC4150Q(1)
100	2200	D	35 x 95	4.3	23.2	17.6	50	31	12	PEH169PD4220Q(1)
100	3300	H	50 x 75	6.4	33.8	23.8	30	23	16	PEH169PH4330Q(1)
100	4700	J	50 x 95	7.7	37.1	27.6	26	17	16	PEH169PJ4470Q(1)
100	6800	O	65 x 105	10.4	46.4	35.5	18	12	16	PEH169PO4680Q(1)
VDC	Rated Capacitance	Size Code	Reference Size	Ripple Current			ESR		L _{ESL}	Part Number

(1) Mounting Code: U2 = plain can, B2 = threaded mounting stud
² 2 m/s forced air, studmounted on 3°C/W aluminum chassis.

Table 1 – Ratings & Part Number Reference cont'd

VDC	Rated Capacitance 100 Hz 20°C (µF)	Size Code	Reference Size D x L (mm)	Ripple Current Maximum			ESR Maximum		L _{ESL} Approximate (nH)	Part Number
				100 Hz 105°C (A)	10 kHz 50°C (A) ²	10 kHz 40°C (A)	100 Hz 20°C (mΩ)	100 kHz 20°C (mΩ)		
100	10000	O	65 x 105	11.7	49.1	36.6	14	10	16	PEH169PO5100Q(1)
100	15000	U	75 x 115	16.0	67.5	51.1	9	6	17	PEH169PU5150Q(1)
100	22000	V	75 x 145	18.2	70.6	55.3	7	5	17	PEH169PV5220Q(1)
160	330	A	35 x 51	1.4	9.6	6.6	400	210	12	PEH169QA3330Q(1)
160	470	A	35 x 51	1.7	11.2	7.6	290	160	12	PEH169QA3470Q(1)
160	680	C	35 x 75	2.1	13.8	10.3	190	100	12	PEH169QC3680Q(1)
160	1000	D	35 x 95	2.6	15.7	12.3	130	70	12	PEH169QD4100Q(1)
160	1500	H	50 x 75	3.8	22.1	16.2	93	51	16	PEH169QH4150Q(1)
160	2200	J	50 x 95	4.7	25.4	19.6	64	36	16	PEH169QJ4220Q(1)
160	3300	O	65 x 105	6.5	32.0	25.0	45	26	16	PEH169QO4330Q(1)
160	4700	T	75 x 105	8.7	48.1	36.9	26	13	17	PEH169QT4470Q(1)
160	6800	U	75 x 115	10.2	50.9	39.6	19	10	17	PEH169QU4680Q(1)
160	10000	V	75 x 145	11.9	55.7	43.2	14	8	17	PEH169QV5100Q(1)
200	330	A	35 x 51	1.5	8.1	5.6	480	300	12	PEH169RA3330Q(1)
200	470	B	35 x 60	1.8	9.7	6.9	340	210	12	PEH169RB3470Q(1)
200	680	D	35 x 95	2.2	10.0	7.9	250	160	12	PEH169RD3680Q(1)
200	1000	H	50 x 75	3.3	15.5	11.4	170	110	16	PEH169RH4100Q(1)
200	1500	J	50 x 95	4.0	18.0	14.0	120	76	16	PEH169RJ4150Q(1)
200	2200	K	50 x 105	4.9	23.1	17.2	76	49	16	PEH169RK4220Q(1)
200	3300	O	65 x 105	6.7	28.8	22.0	55	37	16	PEH169RO4330Q(1)
200	4700	T	75 x 105	8.6	41.6	31.1	33	20	17	PEH169RT4470Q(1)
200	6800	V	75 x 145	10.1	45.2	35.2	24	16	17	PEH169RV4680Q(1)
250	150	A	35 x 51	1.0	7.0	4.9	730	370	12	PEH169SA3150Q(1)
250	220	A	35 x 51	1.3	8.9	6.0	500	250	12	PEH169SA3220Q(1)
250	330	B	35 x 60	1.6	11.0	7.7	320	160	12	PEH169SB3330Q(1)
250	470	C	35 x 75	2.0	11.7	8.9	240	130	12	PEH169SC3470Q(1)
250	680	H	50 x 75	2.9	17.2	12.6	170	90	16	PEH169SH3680Q(1)
250	1000	H	50 x 75	3.5	21.0	15.5	110	58	16	PEH169SH4100Q(1)
250	1500	K	50 x 105	4.2	24.1	17.9	79	43	16	PEH169SK4150Q(1)
250	2200	O	65 x 105	5.8	25.8	23.6	56	32	16	PEH169SO4220Q(1)
250	3300	T	75 x 105	7.9	41.5	31.5	36	20	17	PEH169ST4330Q(1)
250	4700	V	75 x 145	9.2	46.6	37.8	26	14	17	PEH169SV4470Q(1)
250	6800	X	75 x 220	9.4	42.6	36.8	19	12	17	PEH169SX4680Q(1)
250	6800	Y	90 x 145	11.9	53.5	43.5	20	12	16	PEH169SY4680Q(1)
350	100	A	35 x 51	1.0	6.7	4.6	810	410	12	PEH169UA3100Q(1)
350	150	A	35 x 51	1.3	8.8	6.1	520	250	12	PEH169UA3150Q(1)
350	220	C	35 x 75	1.5	10.1	7.3	360	180	12	PEH169UC3220Q(1)
350	330	D	35 x 95	1.9	11.8	9.1	250	120	12	PEH169UD3330Q(1)
350	470	H	50 x 75	2.7	17.1	12.3	180	91	16	PEH169UH3470Q(1)
350	680	J	50 x 95	3.3	19.9	14.8	120	64	16	PEH169UJ3680Q(1)
350	1000	K	50 x 105	4.1	24.3	18.0	82	42	16	PEH169UK4100Q(1)
350	1500	O	65 x 105	5.5	30.6	23.5	60	33	16	PEH169UO4150Q(1)
350	2200	T	75 x 105	7.5	42.6	32.6	39	20	17	PEH169UT4220Q(1)
350	3300	V	75 x 145	9.0	44.1	38.0	26	14	17	PEH169UV4330Q(1)
350	4700	X	75 x 220	9.4	41.4	35.9	22	13	17	PEH169UX4470Q(1)
350	4700	Y	90 x 145	11.6	50.8	41.7	23	14	16	PEH169UY4470Q(1)
VDC	Rated Capacitance	Size Code	Reference Size	Ripple Current			ESR		L _{ESL}	Part Number

(1) Mounting Code: U2 = plain can, B2 = threaded mounting stud

² 2 m/s forced air, studmounted on 3°C/W aluminum chassis.

Mechanical Data

Polarity and Reversed Voltage

Aluminium Electrolytic capacitors manufactured for use in DC applications contain an anode foil and a cathode foil. As such, they are polarized devices and must be connected with the +ve to the anode foil and the -ve to the cathode foil. If this were to be reversed then the electrolytic process that took place in forming the oxide layer on the anode would be recreated in trying to form an oxide layer on the cathode. In forming the cathode foil in this way, heat would be generated and gas given off within the capacitor, usually leading to catastrophic failure.

The cathode foil already possesses a thin stabilized oxide layer. This thin oxide layer is equivalent to a forming voltage of approximately 2 V. As a result, the capacitor can withstand a voltage reversal of up to 2 V for short periods. Above this voltage, the formation process will commence. Aluminium Electrolytic capacitors can also be manufactured for use in intermittent AC applications by using two anode foils in place of one anode and one cathode.

Mounting Position

The capacitor can be mounted upright or inclined to a horizontal position.

Clamp Fixing

Clips must be ordered separately.

Stud Fixing

Nylon cap nut must be ordered separately. For the stud fixing insulated version, the outer insulation serves as lock washer.

Maximum tightening torque:

M8 = 3 Nm

M12= 8 Nm

Maximum chassis thickness 5 mm.

Screw Terminals

M5 x 10 according to DIN 41.248.

Maximum tightening torque = 2.5 Nm.

Must be ordered separately.

Recommended maximum connector thickness with delivered screw = 4 mm. M6 thread upon request.

Insulating Cup

PEH169 is supplied with a 0.8 mm thick polypropylene insulating cup. Voltage proof of the insulating cup: $\geq 4,000$ VDC

Marking

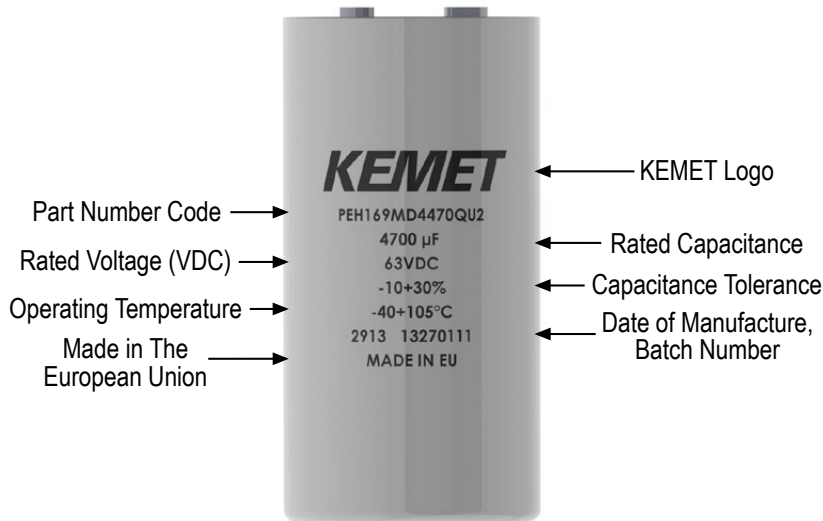

Construction

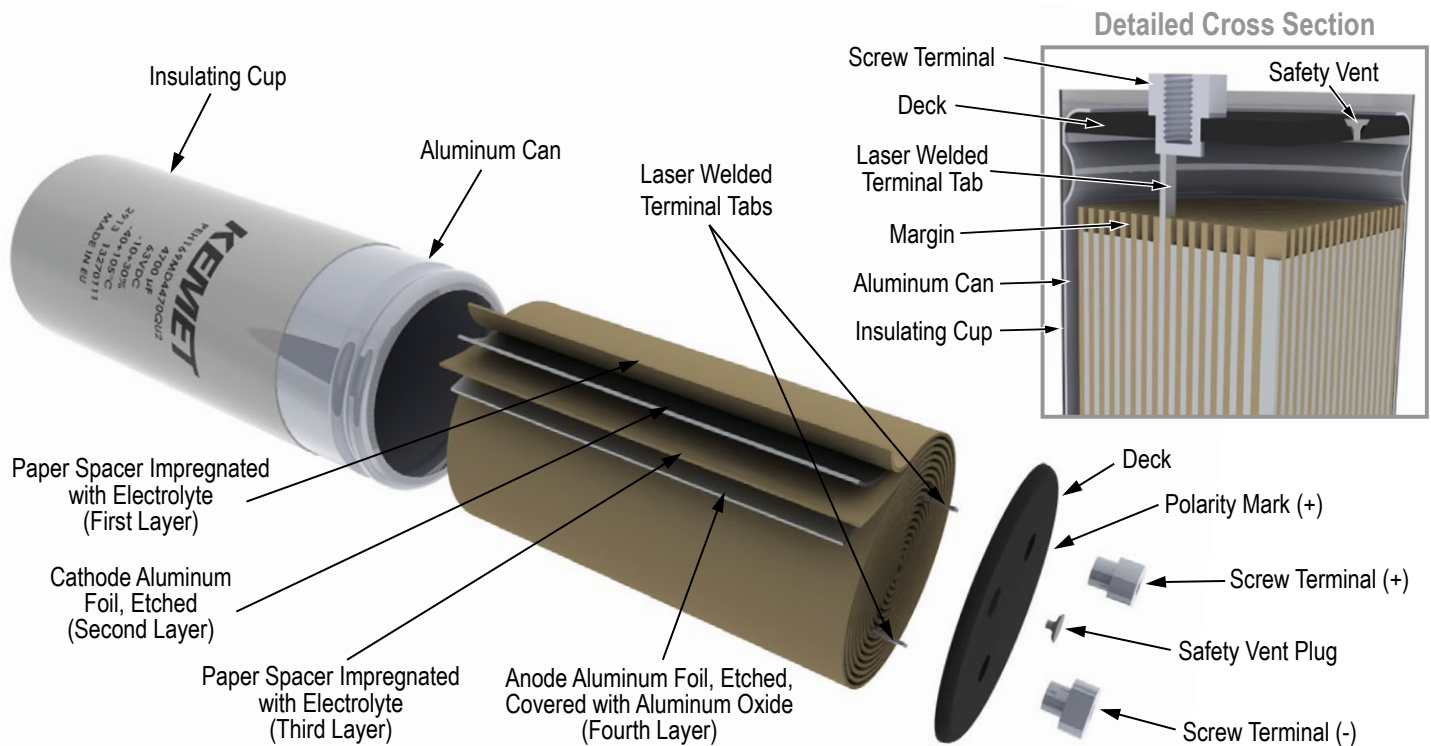

Construction cont'd

The manufacturing process begins with the anode foil being electrochemically etched to increase the surface area and then “formed” to produce the aluminum oxide layer. Both the anode and cathode foils are then interleaved with absorbent paper and wound into a cylinder. During the winding process, aluminum tabs are attached to each foil to provide the electrical contact.

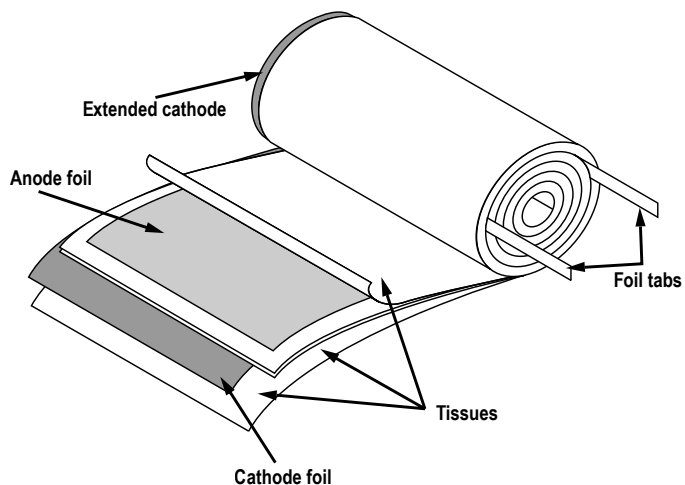

The deck, complete with terminals, is attached to the tabs and then folded down to rest on top of the winding. The complete winding is impregnated with electrolyte before being housed in a suitable container, usually an aluminum can, and sealed. Throughout the process, all materials inside the housing must be maintained at the highest purity and be compatible with the electrolyte.

Each capacitor is aged and tested before being sleeved and packed. The purpose of aging is to repair any damage in the oxide layer and thus reduce the leakage current to a very low level. Aging is normally carried out at the rated temperature of the capacitor and is accomplished by applying voltage to the device while carefully controlling the supply current. The process may take several hours to complete.

Damage to the oxide layer can occur due to variety of reasons:

- Slitting of the anode foil after forming
- Attaching the tabs to the anode foil
- Minor mechanical damage caused during winding

A sample from each batch is taken by the quality department after completion of the production process.

The following tests are applied and may be varied at the request of the customer. In this case the batch, or special procedure, will determine the course of action.

Electrical:

- Leakage current
- Capacitance
- ESR
- Impedance
- Tan Delta

Mechanical/Visual:

- Overall dimensions
- Torque test of mounting stud
- Print detail
- Box labels
- Packaging, including packed quantity

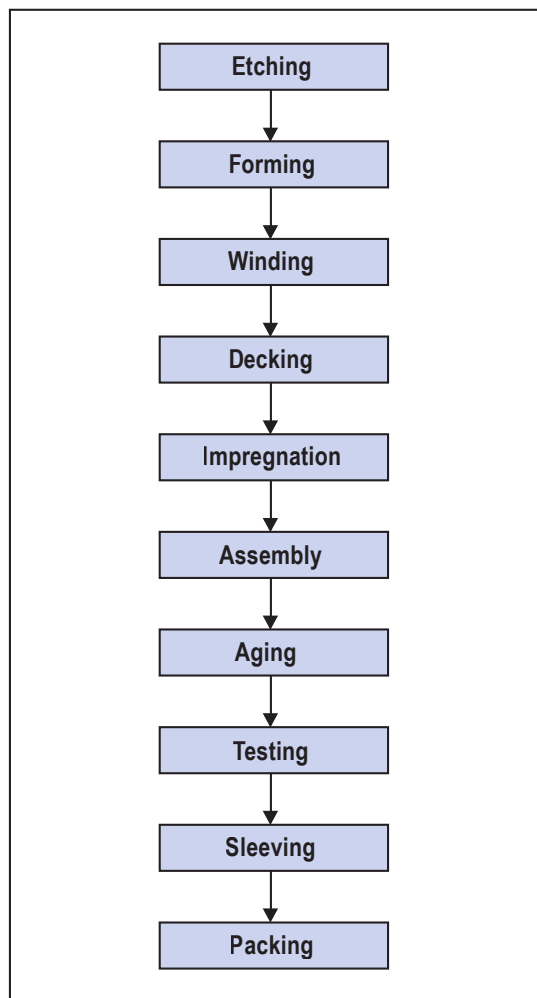

KEMET Corporation World Headquarters

2835 KEMET Way
Simpsonville, SC 29681

Mailing Address:
P.O. Box 5928
Greenville, SC 29606

www.kemet.com
Tel: 864-963-6300
Fax: 864-963-6521

Corporate Offices
Fort Lauderdale, FL
Tel: 954-766-2800

North America

Northeast
Wilmington, MA
Tel: 978-658-1663

Southeast
Lake Mary, FL
Tel: 407-855-8886

Central
Novi, MI
Tel: 248-994-1030

Irving, TX
Tel: 972-915-6041

West
Milpitas, CA
Tel: 408-433-9950

Mexico
Guadalajara, Jalisco
Tel: 52-33-3123-2141

Europe

Southern Europe
Sasso Marconi, Italy
Tel: 39-051-939111

Skopje, Macedonia
Tel: 389-2-55-14-623

Central Europe
Landsberg, Germany
Tel: 49-8191-3350800

Kamen, Germany
Tel: 49-2307-438110

Northern Europe
Wyboston, United Kingdom
Tel: 44-1480-273082

Espoo, Finland
Tel: 358-9-5406-5000

Asia

Northeast Asia
Hong Kong
Tel: 852-2305-1168

Shenzhen, China
Tel: 86-755-2518-1306

Beijing, China
Tel: 86-10-5877-1075

Shanghai, China
Tel: 86-21-6447-0707

Seoul, South Korea
Tel: 82-2-6294-0550

Taipei, Taiwan
Tel: 886-2-27528585

Southeast Asia
Singapore
Tel: 65-6701-8033

Penang, Malaysia
Tel: 60-4-6430200

Bangalore, India
Tel: 91-806-53-76817

Note: KEMET reserves the right to modify minor details of internal and external construction at any time in the interest of product improvement. KEMET does not assume any responsibility for infringement that might result from the use of KEMET Capacitors in potential circuit designs. KEMET is a registered trademark of KEMET Electronics Corporation.

Disclaimer

All product specifications, statements, information and data (collectively, the "Information") in this datasheet are subject to change. The customer is responsible for checking and verifying the extent to which the Information contained in this publication is applicable to an order at the time the order is placed.

All Information given herein is believed to be accurate and reliable, but it is presented without guarantee, warranty, or responsibility of any kind, expressed or implied.

Statements of suitability for certain applications are based on KEMET Electronics Corporation's ("KEMET") knowledge of typical operating conditions for such applications, but are not intended to constitute – and KEMET specifically disclaims – any warranty concerning suitability for a specific customer application or use. The Information is intended for use only by customers who have the requisite experience and capability to determine the correct products for their application. Any technical advice inferred from this Information or otherwise provided by KEMET with reference to the use of KEMET's products is given gratis, and KEMET assumes no obligation or liability for the advice given or results obtained.

Although KEMET designs and manufactures its products to the most stringent quality and safety standards, given the current state of the art, isolated component failures may still occur. Accordingly, customer applications which require a high degree of reliability or safety should employ suitable designs or other safeguards (such as installation of protective circuitry or redundancies) in order to ensure that the failure of an electrical component does not result in a risk of personal injury or property damage.

Although all product-related warnings, cautions and notes must be observed, the customer should not assume that all safety measures are indicated or that other measures may not be required.